



Smarter. Greener. Together.

Industrial Automation Headquarters

Delta Electronics, Inc.

Taoyuan Technology Center
No.18, Xinglong Rd., Taoyuan District,
Taoyuan City 33068, Taiwan
TEL: 886-3-362-6301 / FAX: 886-3-371-6301

Asia

Delta Electronics (Shanghai) Co., Ltd.

No.182 Minyu Rd., Pudong Shanghai, P.R.C.
Post code : 201209
TEL: 86-21-6872-3988 / FAX: 86-21-6872-3996
Customer Service: 400-820-9595

Delta Electronics (Japan), Inc.

Tokyo Office
Industrial Automation Sales Department
2-1-14 Shibadaimon, Minato-ku
Tokyo, Japan 105-0012
TEL: 81-3-5733-1155 / FAX: 81-3-5733-1255

Delta Electronics (Korea), Inc.

Seoul Office
1511, 219, Gasan Digital 1-Ro., Geumcheon-gu,
Seoul, 08501 South Korea
TEL: 82-2-515-5305 / FAX: 82-2-515-5302

Delta Energy Systems (Singapore) Pte Ltd.

4 Kaki Bukit Avenue 1, #05-04, Singapore 417939
TEL: 65-6747-5155 / FAX: 65-6744-9228

Delta Electronics (India) Pvt. Ltd.

Plot No.43, Sector 35, HSIIDC Gurgaon,
PIN 122001, Haryana, India
TEL: 91-124-4874900 / FAX : 91-124-4874945

Delta Electronics (Thailand) PCL.

909 Soi 9, Moo 4, Bangpoo Industrial Estate (E.P.Z),
Pattana 1 Rd., T.Phraksa, A.Muang,
Samutprakarn 10280, Thailand
TEL: 66-2709-2800 / FAX : 662-709-2827

Delta Energy Systems (Australia) Pty Ltd.

Unit 20-21/45 Normanby Rd., Notting Hill Vic 3168, Australia
TEL: 61-3-9543-3720

Americas

Delta Electronics (Americas) Ltd.

Raleigh Office
P.O. Box 12173, 5101 Davis Drive,
Research Triangle Park, NC 27709, U.S.A.
TEL: 1-919-767-3813 / FAX: 1-919-767-3969

Delta Greentech (Brasil) S/A

São Paulo Office
Rua Itapeva, 26 – 3º Andar - Bela Vista
CEP: 01332-000 – São Paulo – SP - Brasil
TEL: 55-11-3530-8642 / 55-11-3530-8640

Delta Electronics International Mexico S.A. de C.V.

Mexico Office
Vía Dr. Gustavo Baz No. 2160, Colonia La Loma,
54060 Tlalneantla Estado de Mexico
TEL: 52-55-2628-3015 #3050/3052

EMEA

Headquarters: Delta Electronics (Netherlands) B.V.

Sales: Sales.IA.EMEA@deltaww.com
Marketing: Marketing.IA.EMEA@deltaww.com
Technical Support: iatechnicalsupport@deltaww.com
Customer Support: Customer-Support@deltaww.com
Service: Service.IA.emea@deltaww.com
TEL: +31(0)40 800 3800

BENELUX: Delta Electronics (Netherlands) B.V.

De Witbogt 20, 5652 AG Eindhoven, The Netherlands
Mail: Sales.IA.Benelux@deltaww.com
TEL: +31(0)40 800 3800

DACH: Delta Electronics (Netherlands) B.V.

Coesterweg 45, D-59494 Soest, Germany
Mail: Sales.IA.DACH@deltaww.com
TEL: +49(0)2921 987 0

France: Delta Electronics (France) S.A.

ZI du bois Challand 2, 15 rue des Pyrénées,
Lisses, 91090 Evry Cedex, France
Mail: Sales.IA.FR@deltaww.com
TEL: +33(0)1 69 77 82 60

Iberia: Delta Electronics Solutions (Spain) S.L.U

Ctra. De Villaverde a Vallecas, 265 1º Dcha Ed.
Hormigueras – P.I. de Vallecas 28031 Madrid
TEL: +34(0)91 223 74 20
C/Llull, 321-329 (Edifici CINC) | 22@Barcelona, 08019 Barcelona
Mail: Sales.IA.Iberia@deltaww.com
TEL: +34 93 303 00 60

Italy: Delta Electronics (Italy) S.r.l.

Ufficio di Milano Via Senigallia 18/2 20161 Milano (MI)
Piazza Grazioli 18 00186 Roma Italy
Mail: Sales.IA.Italy@deltaww.com
TEL: +39 02 64672538

Russia: Delta Energy System LLC

Vereyskaya Plaza II, office 112 Vereyskaya str.
17 121357 Moscow Russia
Mail: Sales.IA.RU@deltaww.com
TEL: +7 495 644 3240

Turkey: Delta Greentech Elektronik San. Ltd. Sti. (Turkey)

Şerifali Mah. Hendem Cad. Kule Sok. No:16-A
34775 Ümraniye – İstanbul
Mail: Sales.IA.Turkey@deltaww.com
TEL: + 90 216 499 9910

GCC: Delta Energy Systems AG (Dubai BR)

P.O. Box 185668, Gate 7, 3rd Floor, Hamarain Centre
Dubai, United Arab Emirates
Mail: Sales.IA.MEA@deltaww.com
TEL: +971(0)4 2690148

Egypt + North Africa: Delta Electronics

511 Cairo Business Plaza, North 90 street,
New Cairo, Cairo, Egypt
Mail: Sales.IA.MEA@deltaww.com



TP70P-211LC1T/ TP04P-20EXL1T Operation Manual

www.deltaww.com



Smarter. Greener. Together.

TP70P-211LC1T/TP04P-20EXL1T

REVISION HISTORY

Version	Revision	Date
1 st	The first version was published.	2019/2/20

TP70P-211LC1T/TP04P-20EXL1T

Table of Contents

Chapter 1 Introduction

1.1	Overview	1-2
1.2	Related Manuals	1-2
1.3	Model Descriptions	1-3
1.3.1	TP70P-211LC1T	1-3
1.3.2	TP04P-20EXL1T	1-4
1.3.3	Inputs and Outputs	1-4

Chapter 2 Specifications and Functions

2.1	Profile and Arrangement of Terminals	2-2
2.1.1	TP70P-211LC1T	2-2
2.1.2	TP04P-20EXL1T	2-6
2.2	Specifications and Functions	2-10
2.2.1	Functional Specifications	2-10
2.2.1.1	TP70P-211LC1T	2-10
2.2.1.2	TP04P-20EXL1T	2-11
2.2.2	Electrical Specificaitons	2-12
2.2.3	Digital Input/Output Specifications	2-13
2.2.4	Analog Input/Output Specifications	2-14
2.2.4.1	Electrical Specifications for Analog Output Terminals	2-14
2.2.4.2	Electrical Specifications for Temperature / Current / Analog Input Terminals	2-14
2.2.4.3	Electrical Specifications for Loadcell Terminals	2-15
2.2.4.4	TP70P-211LC1T Electrical Specifications for Analog Voltage / Current Input Terminals	2-16
2.2.4.5	TP04P-20EXL1T Electrical Specifications for Analog Voltage / Current Output Terminals	2-16

Chapter 3 Interface Introduction

3.1	TP70P-211LC1T Operational Interface	3-2
3.1.1	Load Cell Setup	3-3
3.1.2	Load Cell Calibration Process	3-5
3.1.3	Load Cell Full Screen Display	3-7
3.1.4	Analog I/O	3-9

3.1.5	Digital I/O.....	3-10
3.1.6	System Setup.....	3-11
3.2	TP04P-20EXL1T Operational Interface	3-12
3.2.1	Load Cell Setup	3-13
3.2.2	Load Cell Calibration Process	3-14
3.2.3	Load Cell Full Screen Display	3-17

Chapter 4 Installation and Wiring

4.1	Installation.....	4-2
4.2	Wiring	4-3
4.2.1	Wiring Power.....	4-3
4.2.2	Wiring Digital Input Terminals	4-5
4.2.3	Wiring Digital Output Terminals	4-5
4.2.4	Wiring Analog Input Terminals.....	4-6
4.2.5	Wiring Analog Voltage / Current Output Terminals.....	4-7
4.2.6	Wiring Analog Current Output Terminals	4-8
4.2.7	Mixed Analog Input Terminals.....	4-9
4.2.8	Wiring Load Cell Terminals	4-10
4.2.9	Definitions of RS-485 Ports	4-11

Chapter 5 Devices

5.1	Devices.....	5-2
5.2	Special Data Registers.....	5-4
5.3	Special Auxiliary Relay	5-12
5.4	Special Data Registers Specific for TP Series.....	5-21

Chapter 1 Product Introduction

Table of Contents

- 1.1 Overview 1-2**
- 1.2 Related Manuals 1-2**
- 1.3 Model Descriptions 1-3**
 - 1.3.1 TP70P-211LC1T 1-3
 - 1.3.2 TP04P-20EXL1T 1-4
 - 1.3.3 Inputs and Outputs 1-4

1.1 Overview

This manual introduces the product specifications, wiring, functions, interface, corresponding registers, operation and so forth for TP70P-211LC1T and TP04P-20EXL1.

1.2 Related Manuals

The related manuals for TP70P-211LC1T and TP04P-20EXL1T are listed below.

- The installation instructions for TP70P-211LC1T and TP04P-20EXL1T.
An installation instruction is enclosed in the package, introducing important information for the first time user.
- TPEditor User Manual
This introduces the installation, configuration, and operation of the TPEditor software.
- ISPSOFT User Manual
This introduces the use of the ISPSOFT software, programming language (Ladder, IL, SFC, FBD, and ST), POUs, and tasks.

1.3 Model Descriptions

1.3.1 TP70P-211LC1T



Type	7-inch Touch Panel HMI with Built-in PLC	
Model Name	TP70P-211LC1T	
Description	Digital Input / Output	24VDC, 5mA, 17 inputs 12 ~ 24VDC, 0.5A/output, 2.5A/COM, Transistor-T (sinking) (NPN), 24 outputs
	Analog Output	4 analog channel; current 0 ~ 20mA / 4 ~ 20mA
	Analog / Temperature Measurement Input	2 input channel; 0 ~ 5V, 0 ~ 10V, 0 ~ 50mV, 0 ~ 20mA, 4 ~ 20mA; applicable sensors: Pt100 / JPt100 / Pt1000 / Ni100 / Ni1000 / LG-Ni1000 / Cu50 / Cu100; 16-bit resolution
	Load Cell Input	1-channel, 4-wire/6-wire load cell sensor Highest precision: 0.01% ◦ ADC Resolution: 24 bits Conversion time: selectable 2.5 ~ 400ms Variable excitation voltage: 2 ~ 9.5V/250mA
	Communication Port	Isolated USB (COM1) & Isolated RS-485 (COM2/COM3)

1.3.2 TP04P-20EXL1T

1



Type	Text Panel HMI with Built-in PLC	
Model Name	TP04P-20EXL1T	
Description	Digital Input / Output	24VDC, 5mA, 9 inputs 12-24VDC, 0.5A/output, 2.5A/COM, Transistor-T (sinking) (NPN), 16 outputs
	Analog Input	-10 ~ +10V, -20mA ~ +20mA, 4 ~ 20mA, 4 inputs; 12-bit resolution
	Analog Output	4 analog channel; current 0 ~ 20mA / 4 ~ 20mA 2 analog channel; voltage: -10 ~ +10V; current: 0mA ~ 20mA / 4 ~ 20mA
	Analog / Temperature Measurement Input	2 input channel; 0 ~ 5V, 0 ~ 10V, 0 ~ 50mV, 0 ~ 20mA, 4 ~ 20mA; applicable sensor: Pt100 / JPt100 / Pt1000 / Ni100 / Ni1000 / LG-Ni1000 / Cu50 / Cu100; 16-bit resolution
	Load Cell Input	1-channel, 4-wire/6-wire load cell sensor Highest precision: 0.01% · ADC Resolution: 24 bits Conversion time: selectable 2.5 ~ 400ms Variable excitation voltage: 2 ~ 9.5V/250mA
	Communication Port	Isolated USB (COM1) & Isolated RS-485 (COM2/COM3)

1.3.3 Inputs and Outputs

Models	Digital Input	Digital Output	Analog Input	Analog Output	Analog / Temperature Measurement Input	Load Cell Input	Output Type
TP70P-211LC1T	17	24	-	4	2AX	1LC	Sinking (NPN)
TP04P-20EXL1T	9	16	4	6	2AX	1LC	Sinking (NPN)

Chapter 2 Specifications and Functions

Table of Contents

2.1	Profile and Arrangement of Terminals	2-2
2.1.1	TP70P-211LC1T	2-2
2.1.2	TP04P-20EXL1T	2-6
2.2	Specifications and Functions	2-10
2.2.1	Functional Specifications	2-10
2.2.1.1	TP70P-211LC1T	2-10
2.2.1.2	TP04P-20EXL1T	2-11
2.2.2	Electrical Specificaitons	2-12
2.2.3	Digital Input/Output Specifications	2-13
2.2.4	Analog Input/Output Specifications.....	2-14
2.2.4.1	Electrical Specifications for Analog Output Terminals.....	2-14
2.2.4.2	Electrical Specifications for Temperature / Current / Analog Input Terminals	2-14
2.2.4.3	Electrical Specifications for Loadcell Terminals	2-15
2.2.4.4	TP70P-211LC1T Electrical Specifications for Analog Voltage / Current Input Terminals	2-16
2.2.4.5	TP04P-20EXL1T Electrical Specifications for Analog Voltage / Current Output Terminals	2-16

2.1 Profile and Arrangement of Terminals

2.1.1 TP70P-211LC1T

- Profile

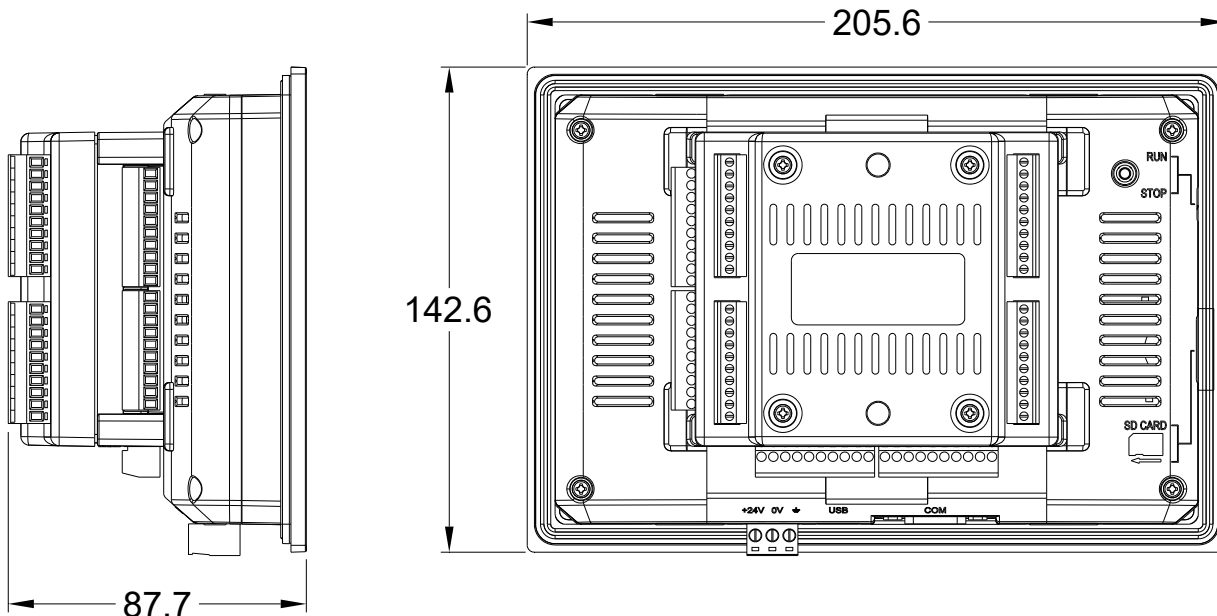

Unit: mm

- Opening Dimensions

The opening size should be within the tolerance limits of ± 0.1 mm to ensure a waterproof and dustproof installation.

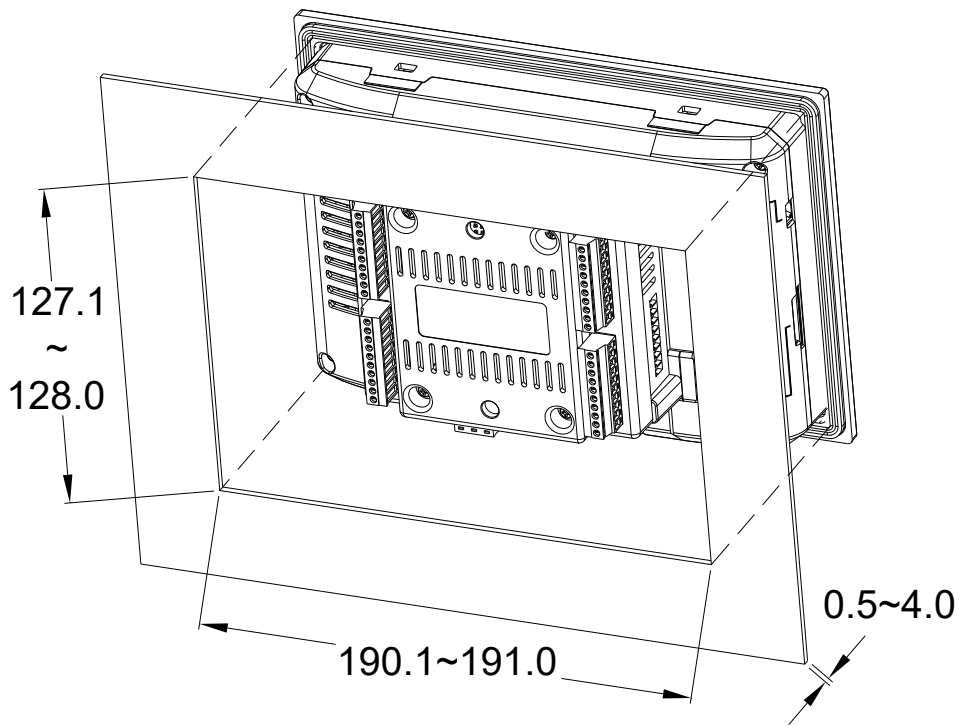

Unit: mm

● **Arrangement of Terminals**

Terminals on the I/O board

①
C2
Y20
Y21
Y22
Y23
Y24
Y25
Y26
Y27
•
②
S/S2
X20
•
IO1
IO2
IO3
IO4
AGND
AGND
•

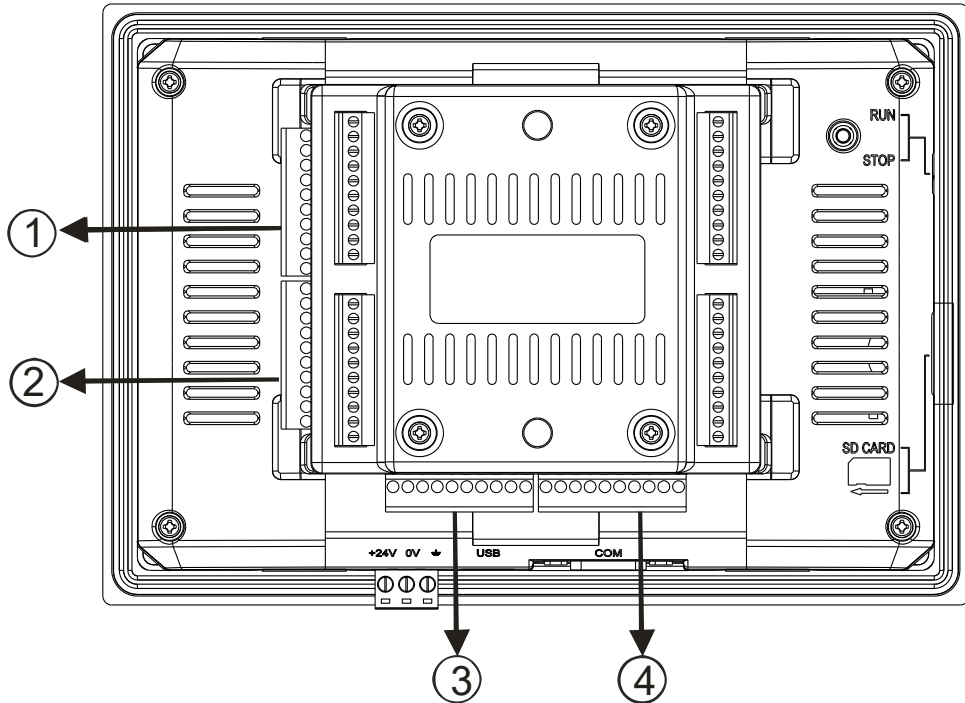

③
•
•
SLD
SLD
SEN-
SEN+
SIG-
SIG+
EXC-
EXC+
④
L1+
I1+
L1-
AGND
L2+
I2+
L2-
AGND
FG
•

Terminals on the drive board

2

⑤
S/S0
X0
X1
X2
X3
X4
X5
X6
X7
•
⑥
S/S1
X10
X11
X12
X13
X14
X15
X16
X17
•

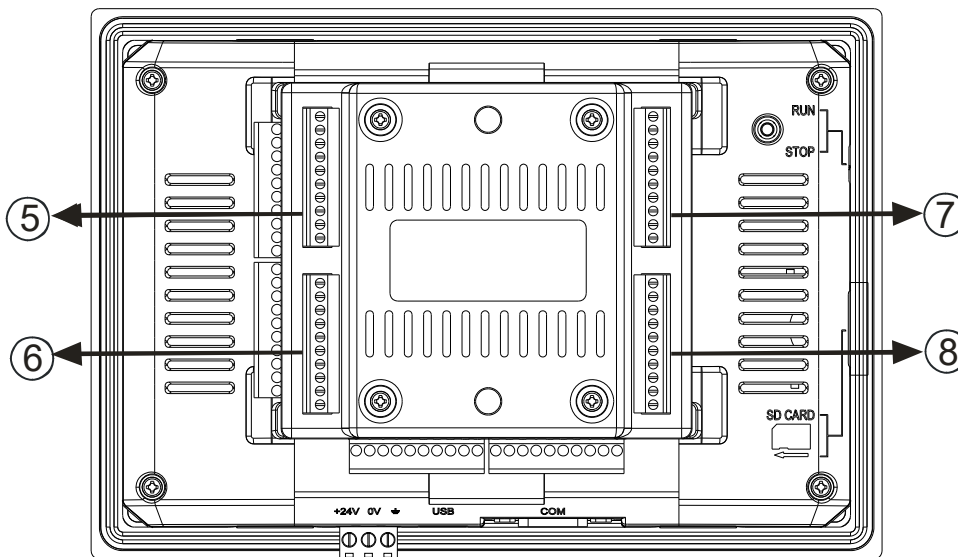

⑦
C0
Y0
Y1
Y2
Y3
Y4
Y5
Y6
Y7
•
⑧
C1
Y10
Y11
Y12
Y13
Y14
Y15
Y16
Y17
•

● Descriptions

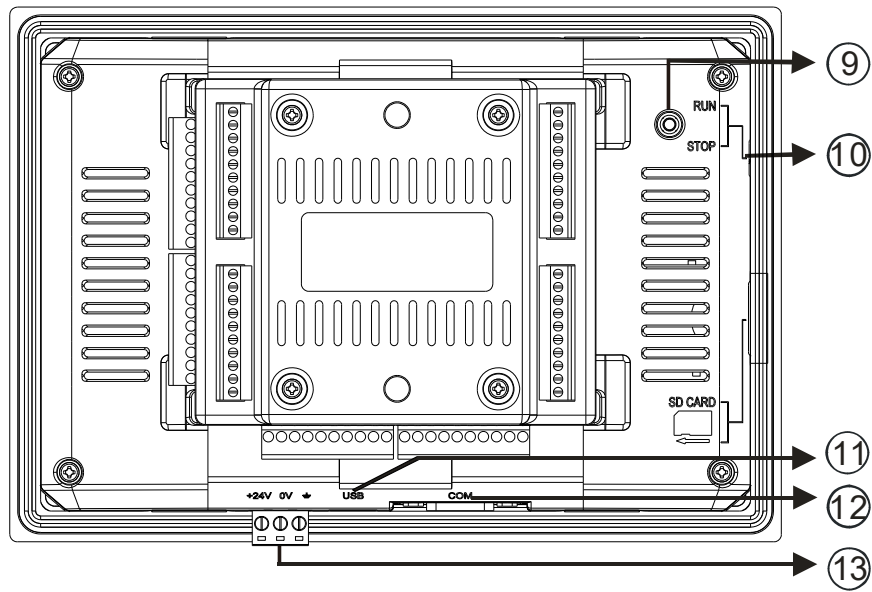

2

Number	Description
⑨	Reset button
⑩	RUN/STOP switches
⑪	USB port for programs to be uploaded or downloaded
⑫	RS-485 communications (two sets of RS-485 communicaiton interfaces)
⑬	DC power

2.1.2 TP04P-20EXL1T

- Profile

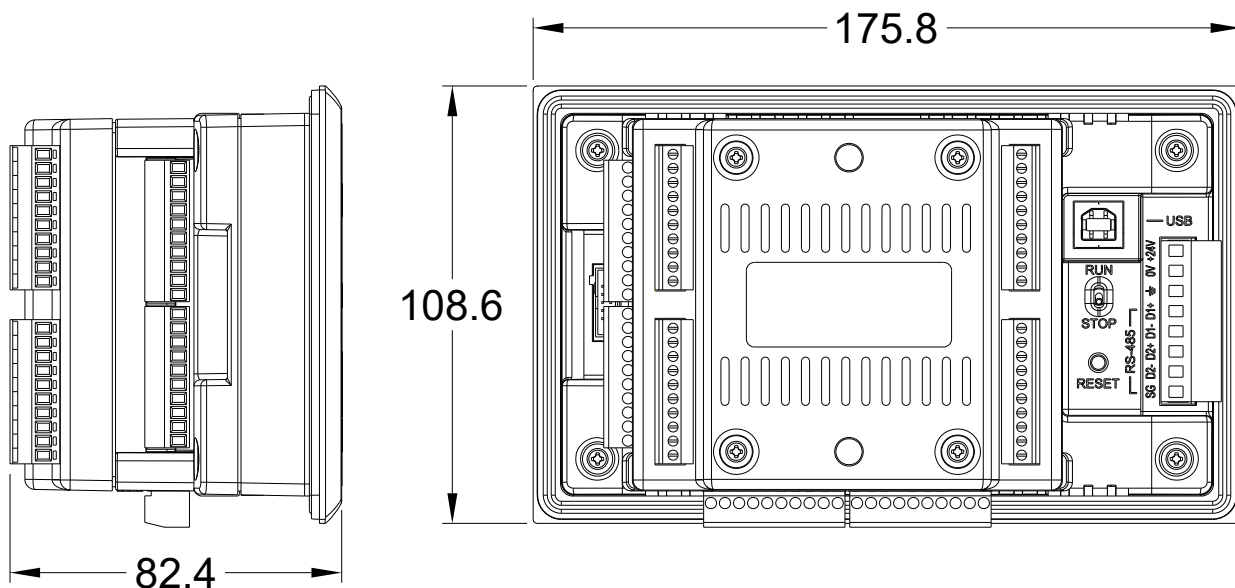

Unit: mm

- Opening Dimensions

The opening size should be within the tolerance limits of ± 0.1 mm to ensure a waterproof and dustproof installation.

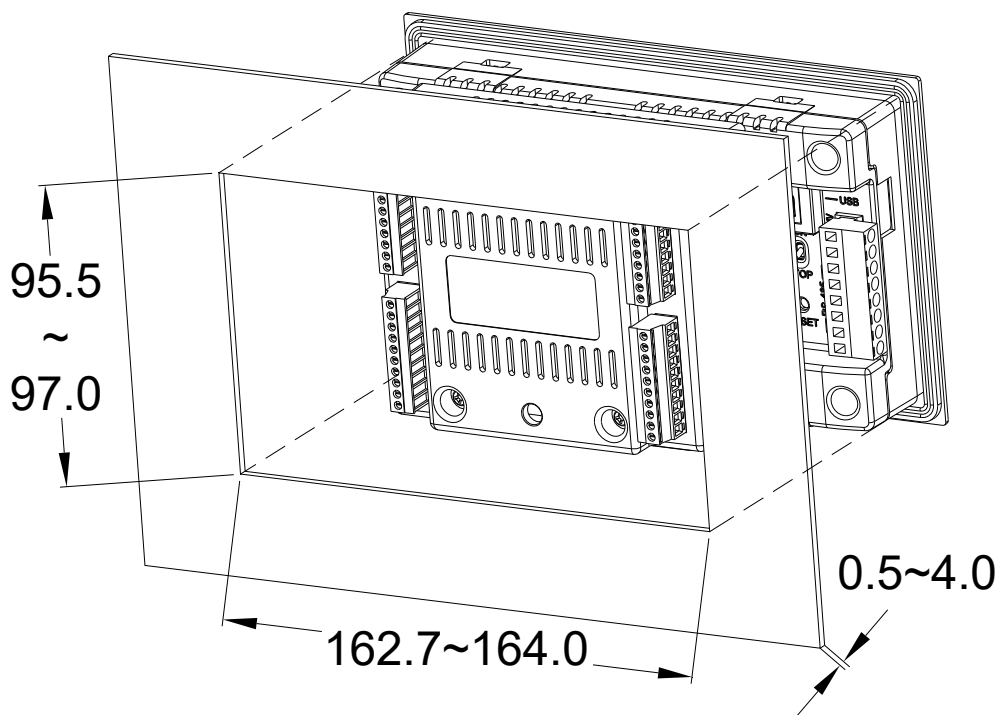

Unit: mm

● Arrangement of Terminals

Terminals on the I/O board

①
C2
Y20
Y21
Y22
Y23
Y24
Y25
Y26
Y27
•
②
S/S2
X20
•
IO1
IO2
IO3
IO4
AGND
AGND
•

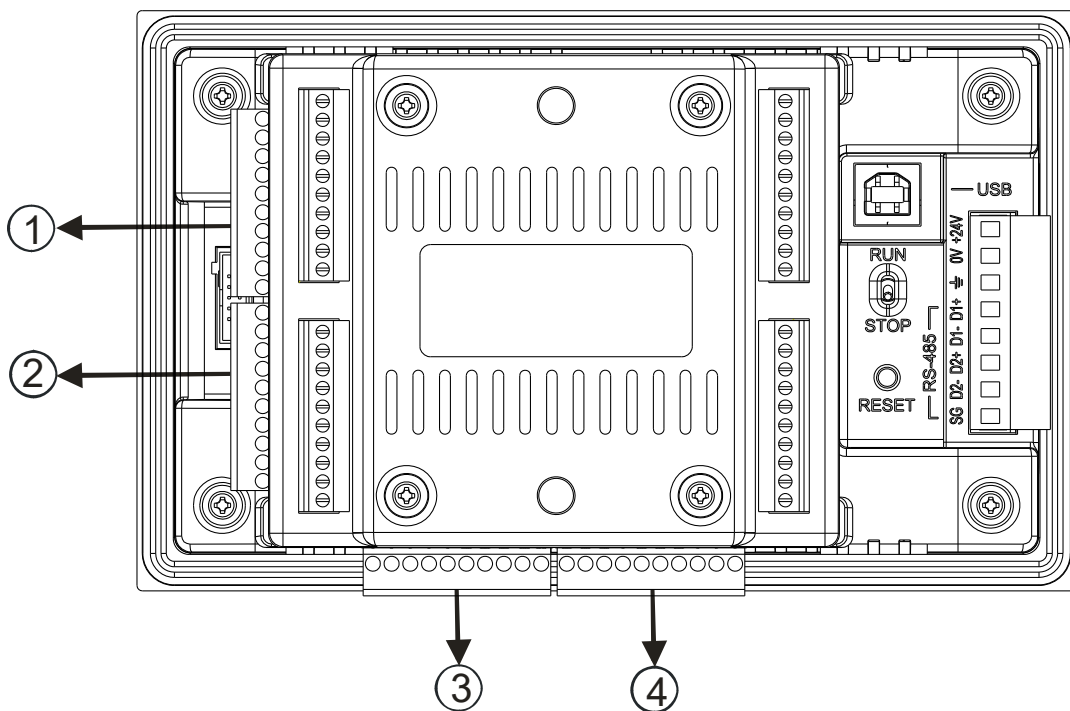

•
FG
AGND
L2-
L2+
AGND
L1-
L1+
④
EXC+
EXC-
SIG+
SIG-
SEN+
SEN-
SLD
SLD
•
•
③

Terminals on the drive board

2

⑤
S/S0
X0
X1
X2
X3
X4
X5
X6
X7
•
⑥
V0+
V0-
I0
V1+
V1-
I1
V2+
V2-
I2
FE

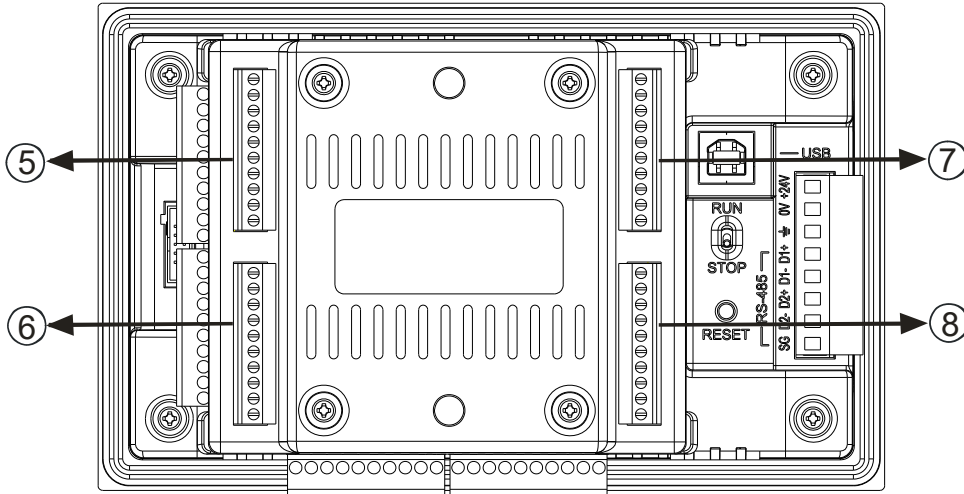

⑦
C0
Y0
Y1
Y2
Y3
Y4
Y5
Y6
Y7
•
⑧
V3+
V3-
I3
FE
V4
I4
AG
V5
I5
AG

● Descriptions

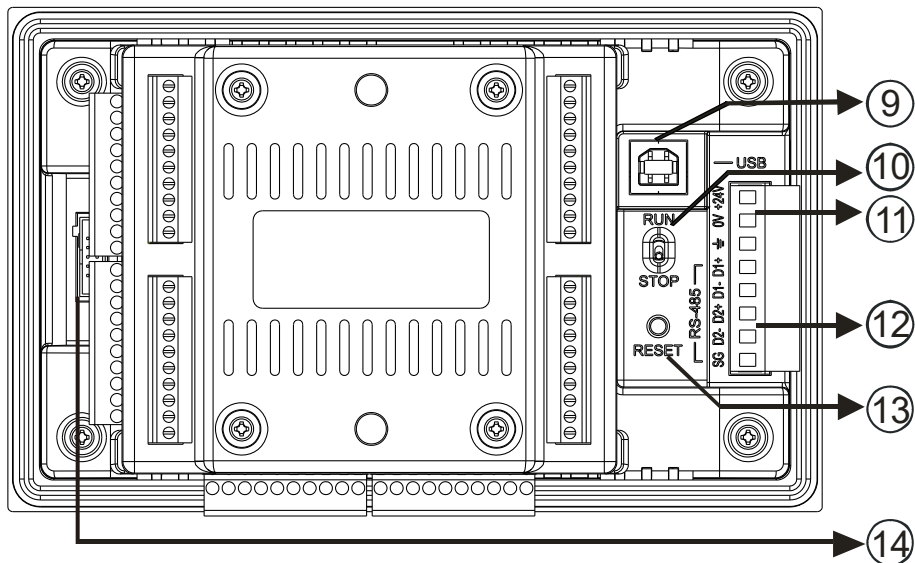

Number	Description
⑨	USB port for programs to be uploaded or downloaded
⑩	RUN/STOP switches
⑪	DC power
⑫	RS-485 communications (two sets of RS-485 communicaiton interfaces)
⑬	Reset button
⑭	Slot for a program card

2.2 Specifications and Functions

2.2.1 Functional Specifications

2.2.1.1 TP70P-211LC1T

Specifications		Model	TP70P-211LC1T
Display	Screen/Color		7" TFT LCD (65535 colors)
	Resolution		800×480 pixels
	Backlight type		LED backlight (It has a lifespan of 20,000 hours at a temperature of 25°C)
	Display area		Width × Height = 154 × 85 (Unit: mm); 7 inches (diagonal)
USB (COM1) USB port for programs to be uploaded or downloaded			Transmission: Virtual communication port Data length: 7 bits or 8 bits Stop bit: 1 bit or 2 bits Parity check: None/Odd/Even Transmission rate: 9,600 bps~115,200 bps USB port: Type B USB connector Isolated communication
RS-485 (Extension Communication Ports)	COM2 (supporting PLC mode)		Data length: 7 bits or 8 bits Stop bit: 1 bit or 2 bits Parity check: None/Odd/Even Transmission rate: 9,600 bps~115,200 bps
	COM3 (supporting TP mode)		Connector: Male DB-9 connector Isolated communication
Downloading and Monitoring			Programs can be downloaded to TP via a virtual communication port of TP.
PLC Program Capacity			4 K steps
Screen Capacity			8 Mbytes

2.2.1.2 TPO4P-20EXL1T

Specifications		Model	TP04P-20EXL1T
Display	Screen/Color		STN-LCD / monochromatic color
	Resolution		192 × 64 pixels
	Backlight Type		Time for the backlight to dim out: 1-99 minutes (0 indicates backlight stays ON) LED backlight (It has a lifespan of 50,000 hours at a temperature of 25°C)
	Display Area		Width × Height = 101.8 × 35.24 (Unit: mm); 4.1 inches (diagonal)
	Language		ASCII: (Code page 850), Alphanumeric (including European characters), Taiwan: (Big 5 codes) Traditional Chinese Fonts, China: (GB2324-80 codes) Simplified Chinese Fonts
	Font Size		ASCII : 5 × 8, 8 × 8, 8 × 12, 8 × 16
	Text on the Display		5×8 pixel fonts: 38 characters × 8 rows; 8×12 pixel fonts: 24 characters × 5 rows 8×8 pixel fonts: 24 characters × 8 rows; 8×16 pixel fonts: 24 characters × 4 rows
	Contrast Adjustment		10 levels (set via TPEditor)
	Function Keys / Number Keys		0 ~ 9, ESC, F, Enter and Up/Down/Left/Right
Alarm Indicators (Green)		Power indicator (blinks for 3 times) / Communication error alarm / user defined indicator	
USB (COM1) USB port for programs to be uploaded or downloaded			Transmission: Virtual communication port Data length: 7 bits or 8 bits Stop bit: 1 bit or 2 bits Parity check: None/Odd/Even Transmission rate: 9,600 bps~115,200 bps USB port: Type B USB connector Isolated communication
RS-485 (Extension Communication Ports)	COM2 (supporting PLC mode)		Data length: 7 bits or 8 bits Stop bit: 1 bit or 2 bits Parity check: None/Odd/Even Transmission rate: 9,600 bps~115,200 bps
	COM3 (supporting TP mode)		Connector: 8-PIN removable terminal block (shared by COM2 and COM3) Isolated communication
Downloading and Monitoring			Programs can be downloaded to TP via a virtual communication port of TP.
PLC Program Capacity			8 K steps
Screen Capacity			8 M bytes
Extension Interface			Slot for a program card
Panel Component	Alarm Indicator (Red)		State 1: when the power is ON, the indicator starts to blink until the power is fully supplied and then the indicator dims out. State 2: when the specified criteria is met, the indicator blinks for 3 seconds and then make a beep sound.
	Power Indicator (Green)		When the power is ON, this indicator is ON.

Specifications		Model	TP04P-20EXL1T
	Display		LCD display; shows the current status
	Number Keys		0 ~ 9: can be used as number keys or user-defined function keys (user can define function keys in TPEditor)
	Function Keys		User-define
	Enter Key (ENT)		Use ENT key to confirm and save the setting; users can also self-define.
	Command Keys		UP: Use this key to increase the setting value or go to the previous page. DOWN: Use this key to decrease the setting value or go to the next page. LEFT: Use this key to set up the parameters. RIGHT: Use this key to set up the parameters. Users can also define command keys in TPEditor.

2.2.2 Electrical Specifications

Item	Model	TP70P-211LC1T	TP04P-20EXL1T
CPU		32-bit ARM Cortex-M4 MCU	LPC1787FBD0208
Supply voltage		24 VDC (-15% ~ 20%) (DC input power polarity reversal protection)	
Power consumption (W)		11W max	
Power protection		DC input power polarity reversal protection	
Insulation impedance		> 5 MΩ (The voltage between all I/O terminals and the ground is 500 V DC.)	
Noise immunity		ESD (IEC 61131-2, IEC 61000-4-2): 8kV Air Discharge EFT (IEC 61131-2 · IEC 61000-4-4): Power Line: 2kV, Digital I/O: 1kV Analog & Communication I/O: 1kV Damped-Oscillatory Wave: Power Line: 1kV, Digital I/O: 1kV RS (IEC 61131-2, IEC 61000-4-3): 26MHz ~ 1GHz, 10V/m	
Ground		The diameter of the ground used should not be less than the diameters of the wires connected to the PLC power terminals. (If several PLCs are used simultaneously, use single-point ground.)	
Battery		3 V CR2032 battery	
Battery lifespan		3 years at a temperature of 25°C	
Operating temperature		0°C~50°C Relative humidity: 20%~90% RH (No condensation)	
Storage temperature		-20°C ~ 60°C	
Panel protection rating		Equivalent to NEMA 4 / IP66	NEMA 4 / IP66
Vibration / Shock resistance		International standards IEC61131-2, IEC 68-2-6 (TEST Fc) / IEC61131-2 & IEC 68-2-27 (TEST Ea)	
Cooling		Transfer of thermal energy via convection	
Connector type		Removable terminal blocks	
Weight		850 g	550 g

2.2.3 Digital Input/Output Specifications

Item		Model	Electrical specifications for digital input terminals	
			24VDC (-15% ~ 20%) single common terminal	
Number of inputs	TP70P-211LC1T		17	
	TP04P-20EXL1T		9	
Connector type			Removable terminal blocks	
Electrical isolation			Optocoupler	
Input form			Direct current: (sinking or sourcing) Sinking: NPN Sourcing: PNP	
Input voltage ($\pm 10\%$)			24 VDC, 5 mA	
Input impedance			4.7 k Ω	
Input terminal	TP70P-211LC1T	X0, X1	X2 ~ X7, X10 ~ X17, X20	
	TP04P-20EXL1T	X0, X1	X2 ~ X7, X20	
Maximum input frequency			10 kHz	60 Hz
Action level	OFF→ON		> 16.5 VDC	
	ON→OFF		< 8 VDC	
Response time	OFF→ON		< 20 μ s	10 ms
	ON→OFF		< 50 μ s	

Item		Model	Electrical specifications for digital output terminals	
			Number of outputs	
		TP04P-20EXL1T	16	
Connector type			Removable terminal blocks	
Electrical isolation			Optocoupler	
Output terminal	TP70P-211LC1T	Y0, Y1	Y2 ~ Y7, Y10 ~ Y17, Y20 ~ Y27	
	TP04P-20EXL1T	Y0, Y1	Y2 ~ Y7, Y20 ~ Y27	
Output form			Transistor, Sinking (NPN: whose collectors are open collectors.)	
Voltage			12 ~ 24VDC	
Current			0.5A/output (2.5A/COM)	
Response time	OFF→ON		Approximately 50 μ s	Approximately 10 ms
	ON→OFF			
Maximum output frequency			10 kHz	50 Hz

2.2.4 Analog Input/Output Specifications

2.2.4.1 Electrical Specifications for Analog Output Terminals

Item	Model	TP70P-211LC1T / TP04P-20EXL1T
Number of channels for analog output		4 (IO1~IO4)
Analog output range		4 ~ 20 mA, 0 ~ 20 mA
Digital conversion range		0 ~ 32000
Resolution		15 bits
Output impedance		100 Ω
Overall accuracy		When reached full scale at 25°C (77°F), the range of error is $\pm 0.2\%$. When reached full scale between 0~55°C (32~131°F), the range of error is $\pm 0.5\%$.
Response time		2 ms
Isolation		No isolation
Maximum output current (Allowable load)		< 500 Ω
Protection		Short circuit protection

2.2.4.2 Electrical Specifications for Temperature / Current / Analog Input Terminals

Item	Model	TP70P-211LC1T / TP04P-20EXL1T
Number of channels for analog input		2 (L1, L2)
Input form		Thermal resistance Voltage / current input mode (divider type)
Applicable sensor		2-wired / 3-wired Pt100, JPt100, Pt1000, Cu50, Cu100, Ni100, Ni1000, LG-Ni1000 -
Analog input range		- Voltage: 0 ~ 5V, 0 ~ 10V, 0 ~ 50mV Current: 0 ~ 20mA, 4 ~ 20mA
Overall accuracy		When reached full scale at 25°C (77°F), the range of error is $\pm 0.4\%$. When reached full scale between 0~55°C (32~131°F), the range of error is $\pm 0.8\%$. When reached full scale at 25°C (77°F), the range of error is $\pm 0.5\%$. When reached full scale between 0~55°C (32~131°F), the range of error is $\pm 1\%$.
Response time		260 ms 130 ms
Digital conversion range		0 ~ 32000 0 ~ 32000
Analog input resolution		16 bits
Thermal conductivity		100 m -
Self-diagnosis		Disconnection detection -
Input impedance		2 M Ω Voltage: 650 K Ω , divider type Current: 249 Ω

2.2.4.3 Electrical Specifications for Load cell Terminals

Item	Model	TP70P-211LC1T / TP04P-20EXL1T
Input Signal Range		±300 mVDC (when the excitation voltage is at 5 VDC)
Sensibility (Variable excitation voltage)		+2 ~ 9.5VDC ±5%
ADC resolution		24 bits
Highest precision		0.01%
Applicable sensor type		4-wire or 6-wire load cell
Expanding a temperature coefficient		≤ ± 20ppm/K v. E
Reducing a temperature coefficient to zero		≤ ± 0.1μV/K
Linearity error		≤ 0.015%
Response time		2.5 · 10 · 16 · 20 · 50 · 60 · 100 · 200 · 400ms
Eigenvalue applicable to a load cell		0.5 ~ 256mV/V, refer to section 3.1.1 for more details
Maximum Distance for Connecting a Load Cell		100 meters
Maximum current consumption		250 mA
Allowable Load		40 ~ 4,010 Ω
Average value filter		1 ~ 100
Extreme value filter		0 ~ 8
Common-mode rejection ratio (CMRR)		100 dB

2.2.4.4 TP70P-211LC1T

Electrical Specifications for Analog Voltage / Current Input Terminals

Item \ Model	TP70P-211LC1T	
Number of inputs	4 (V0+ ~ V3+)	4 (I0 ~ I3)
Input form	Voltage (differential input)	Current (differential input)
Analog input range	±10 V	±20 mA
Digital conversion range	±2000	±1000
Resolution	12bits (1 LSB = 5 mV)	11bits (1 LSB = 20 μA)
Input impedance	1M Ω	250 Ω
Overall accuracy	When reached full scale at 25°C (77°F), the range of error is ±0.5%. When reached full scale between 0~55°C (32~131°F), the range of error is ±1%.	
Response time	3 ms / channel	
Isolation	No isolation	
Absolute input range	±15 V	±32 mA

2.2.4.5 TP04P-20EXL1T

Electrical Specifications for Analog Voltage / Current Output Terminals

Item \ Model	TP04P-20EXL1T	
Number of outputs	2 (V4 ~ V5)	2 (I4 ~ I5)
Output form	Voltage	Current
Analog output range	±10V	0 ~ 20mA
Digital conversion range	±2000	0 ~ 4000
Resolution	12bits (1 LSB = 5 mV)	12bits (1 LSB = 5 μA)
Output impedance	100 Ω	
Overall accuracy	When reached full scale at 25°C (77°F), the range of error is ±0.5%. When reached full scale between 0~55°C (32~131°F), the range of error is ±1%.	
Response time	3 ms / channel	
Isolation	No isolation	
Absolute output range	±15V	±32mA
Protection	Short circuit protection	

Chapter 3 Interface Introduction

Table of Contents

3.1	TP70P-211LC1T Operational Interface	3-2
3.1.1	Load Cell Setup	3-3
3.1.2	Load Cell Calibration Process	3-5
3.1.3	Load Cell Full Screen Display	3-7
3.1.4	Analog I/O	3-9
3.1.5	Digital I/O.....	3-10
3.1.6	System Setup.....	3-11
3.2	TP04P-20EXL1T Operational Interface	3-12
3.2.1	Load Cell Setup	3-13
3.2.2	Load Cell Calibration Process	3-14
3.2.3	Load Cell Full Screen Display	3-17

With an operational interface, TP70P-211LC1T and TP04P-20EXL1T allow you to perform basic operations before you have your own programs ready. You can check if the connections are well secured, if the set testing functions meet your requirements and many more. This helps you to quickly calibrate your device or troubleshoot problems if they ever occur. Below are the operational interface introductions.

3.1 TP70P-211LC1T Operational Interface

The default operational interface is as the image shown below; you can download the program in Delta's official website:

<http://www.deltaww.com/>

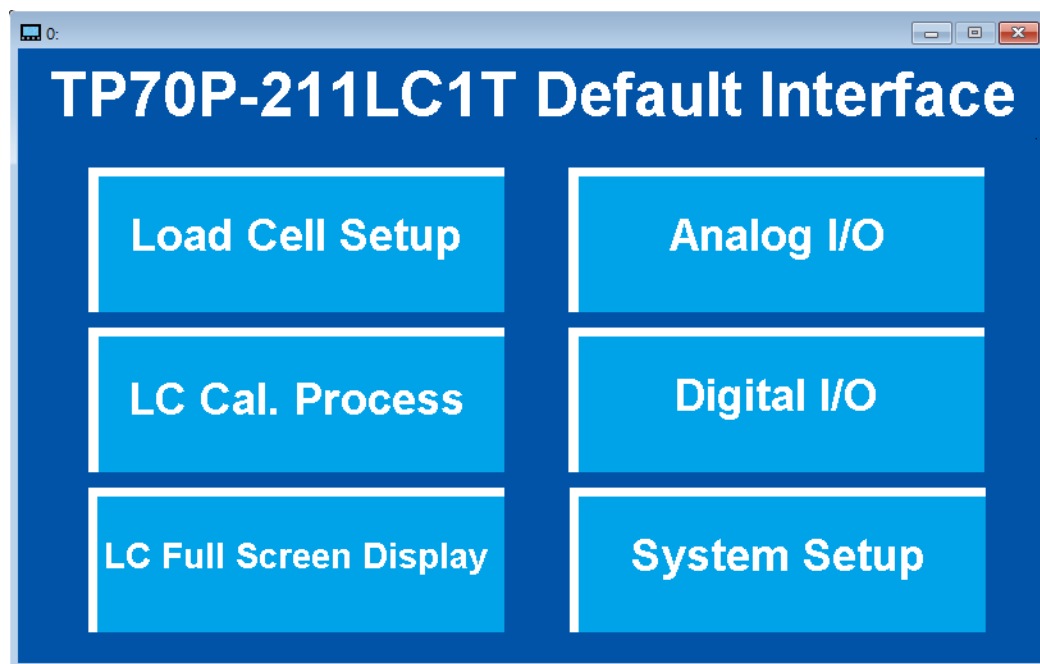

On the main setting menu, you can find six main setting items.

1. Load cell Setup

TP70P-211LC1T is a one-channel load cell with multiple functions. You can use its friendly interface to set up the setting items including excitation voltage, eigenvalue mode, response time mode and configure the parameters for load cell related functions.

2. LC Cal. Process

Before using load cell related functions, you need to calibrate TP70P-211LC1T to ensure the measurements are going to be accurate. Without other software or programs, you can use the **LC Cal. Process** function on the main setting menu to complete the calibration.

3. LC Full Screen Display

Here you can find different kinds of weight values. You can set up how many digits to be shown, select weight units between kilogram and gram, reset the values to zero and many more.

4. Analog I/O

TP70P-211LC1T is with two-channels of multi-analog inputs and four-channels of analog current outputs. You can set up different modes for each channel, read input values and set up output values under this setting item.

5. Digital I/O

TP70P-211LC1T is with 17 input points and 24 output points. You have controls over individual points and you can also read the status of the input points under this setting item.

6. System Setup

In the past, you need to press the **RESET** button to enter the **System Setup** page. Now you can also find **System Setup** page on the main setting menu. You can set up the percentage of the backlight, how long the brightness dims out and many more.

3.1.1 Load Cell Setup

Press **Load Cell Setup** from the main setting menu to display its corresponding setting page. You can always press  in the upper right corner to return to the main setting menu.

There are 10 setting items for you to set up. Press  in the upper left corner to save the settings after each setup or the changes will not be saved.

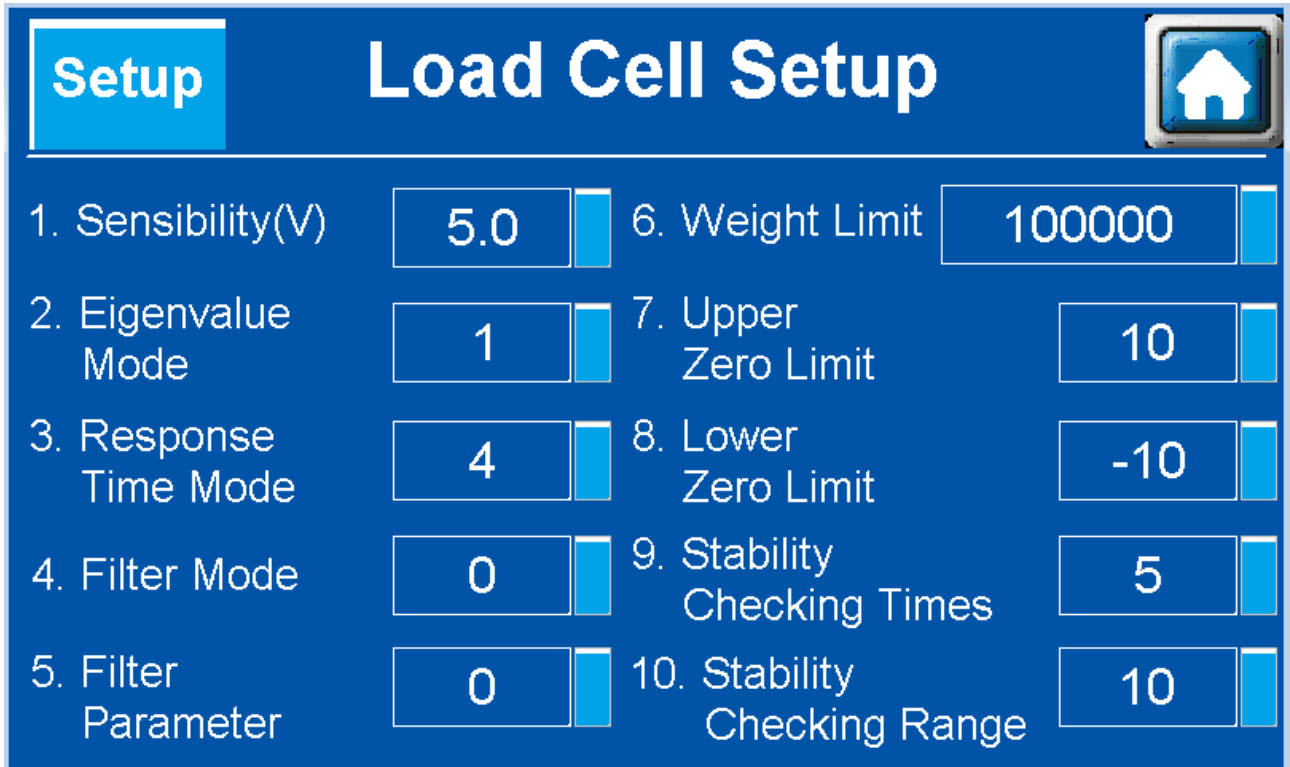

Item	Value
1. Sensibility(V)	5.0
2. Eigenvalue Mode	1
3. Response Time Mode	4
4. Filter Mode	0
5. Filter Parameter	0
6. Weight Limit	100000
7. Upper Zero Limit	10
8. Lower Zero Limit	-10
9. Stability Checking Times	5
10. Stability Checking Range	10

- (1) **Sensibility (V)**: set up the excitation voltage at the load cell, ranging from 2.0 V to 9.5 V.
- (2) **Eigenvalue Mode**: set up the eigenvalue mode from 1 to 9; the excitation voltage in different eigenvalue modes corresponds to different eigenvalues. See the table below for reference.

Excitation voltage	Eigenvalue modes	Eigenvalue (mV/V)	Excitation voltage	Eigenvalue modes	Eigenvalue (mV/V)	Excitation voltage	Eigenvalue modes	Eigenvalue (mV/V)	Excitation voltage	Eigenvalue modes	Eigenvalue (mV/V)
9.5	0	0.5	8.0	0	0.5	6.0	0	0.5	3.5	0	0.5
	1	1		1	1		1	1			
	2	2		2	2		2	2			
	3	3		3	4		3	4			
	4	4		4	8		4	8			
	5	6		5	16		5	16			
	6	7		6	32		6	32			
	7	10		7	50		7	64			
	8	12		8	75		8	128			
9	16	9	100	9	256						

Excitation voltage	Eigenvalue modes	Eigenvalue (mV/V)	Excitation voltage	Eigenvalue modes	Eigenvalue (mV/V)	Excitation voltage	Eigenvalue modes	Eigenvalue (mV/V)	Excitation voltage	Eigenvalue modes	Eigenvalue (mV/V)
9.0	0	0.5	7.0	0	0.5	5.0	0	0.5	2.0	0	0.5
	1	1		1	1		1	1			
	2	2		2	2		2	2			
	3	4		3	4		3	4			
	4	8		4	8		4	8			
	5	12		5	16		5	16			
	6	16		6	32		6	32			
	7	24		7	64		7	64			
	8	32		8	128		8	128			
9	48	9	200	9	256						

(3) **Response Time Mode:** setting range is from 0 to 8; see the modes and their corresponding response times below.

Response time mode	0	1	2	3	4	5	5	7	8
Response time (ms)	2.5	10	16	20	50	60	100	200	400

(4) **Filter Mode:** setting range is from 0 to 2; see the modes and their descriptions below.

Filter Mode	0	1	2
Description	No filter	Maximum value filter	Average value filter

(5) **Filter Parameter:** setting range is from 0 to 8. The bigger the value is set, the more frequent and stronger the filtering is in the maximum value filter mode.

(6) **Weight Limit:** setting range is from 0 to 2^{32} (32-bit value); if the value set is out of range, the system sends out an status code.

(7) **Upper Zero Limit:** setting range is from 0 to 32767 (16-bit value); zero upper limit is defined here.

(8) **Lower Zero Limit:** setting range is from -1 to -32768; zero lower limit is defined here.

(9) **Stability Checking Times:** setting range is from 1 to 500; the system checks if the value is within its setting range for a number of times that is set here.

(10) **Stability Checking Range:** setting range is from 1 to 10000; the system determines if the status is stable by checking if the measured value is within the variation range that is set here. For example, when the value is set to 10, the system checks if the measured value is within this variation range (± 10). When it is in the range, the status is stable and the **Motion** in the bulletin is highlighted in a green block.

3.1.2 Load Cell Calibration Process

Press **LC Cal. Process** from the main setting menu to display its corresponding setting page.

(1) Start Cal. Mode

In setting item 1. **Start Cal. Mode**, press **Push Start** to enter the calibration mode. Once the **Push Start** is pressed, **Start** will be shown instead as the image shown below. This indicates it is in the calibration mode.



(2) Cal. Number Setup

In setting item 2. **Cal. Number Setup**, you can set up the number of points to calibrate; up to 20 points can be set. The example below shows that 3-points setting is set for calibration.

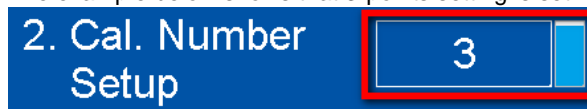

(3) Zero Calibration

Before performing zero calibration, the system checks if the environment is stable. When it is stable, the status shows **Stable** and then a **Push Down** button appears as the image shown below. Press the **Push Down** button to complete zero calibration.

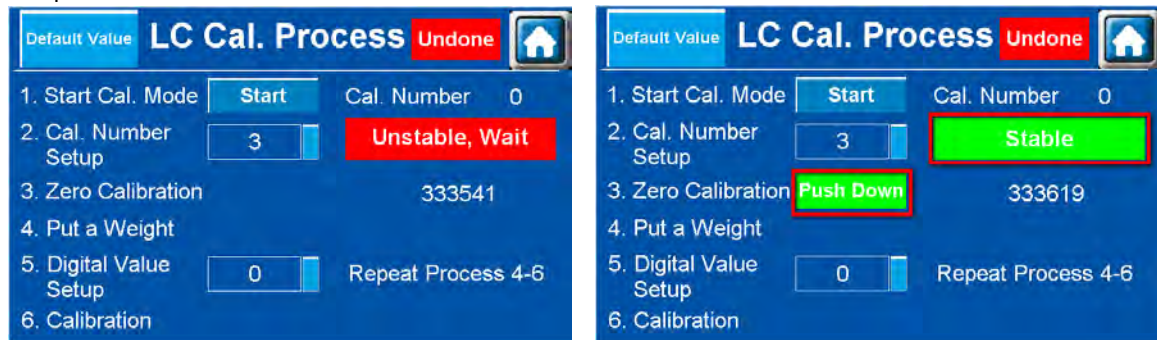

(4) Put a Weight

After zero calibration is complete, the number 2 is the next to be calibrated, see the image below for reference. You can use a standard weight for calibration.

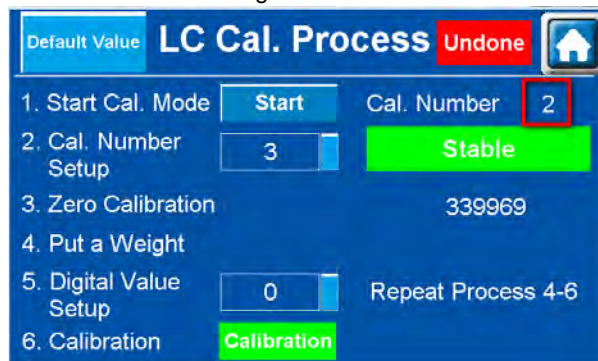

(5) Digital Value Setup

Put an object that you know its weight on the load cell sensor and then enter its digital value for calibration. When the value is settled, the status shows **Stable**. The image below shows an example of using a 100g weight for calibration. Enter the digital value 1000 in the field of **Digital Value Setup**. After the value is settled, the status shows **Stable** and then you can start calibration.

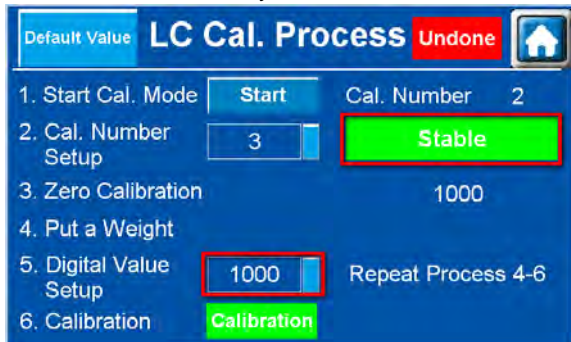

(6) Calibration

The **Stable** shown indicates the value is settled and the **Calibration** button appears at the bottom. Press the **Calibration** button to complete the calibration for the number 2.

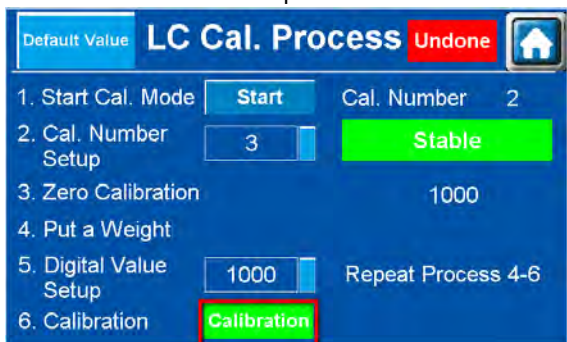

If the number 2 is not the final point set for calibration, the next number appears for calibration. Repeat steps (4) - (6) to complete calibration for all the points. The example below shows that 3-points setting is set for calibration. Thus the number 3 appears for calibration. The image below shows an example of using a 200g weight for calibration. Enter the digital value 2000 in the field of **Digital Value Setup**. After the value is settled, the status shows **Stable** and then press the **Calibration** button to complete the calibration for the number 3.

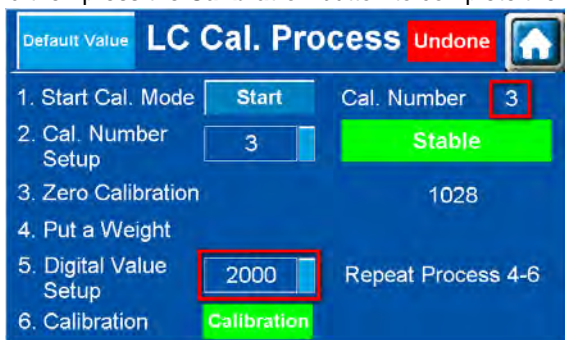

(7) After all calibrations are complete, the LC Cal. Process condition shown in the upper right corner changes from **Undone** in a red block to **Done** in a green block. Press **Storing Data** in the lower right corner to save the settings. Otherwise, the changes will not be saved. Press **Default Value** in the upper left corner to cancel without saving the changes. You can always reset calibrations to default settings by pressing **Default Value** in the upper left corner.



3.1.3 Load Cell Full Screen Display

Press **Load Cell Full Screen Display** from the main setting menu to display its corresponding setting page.

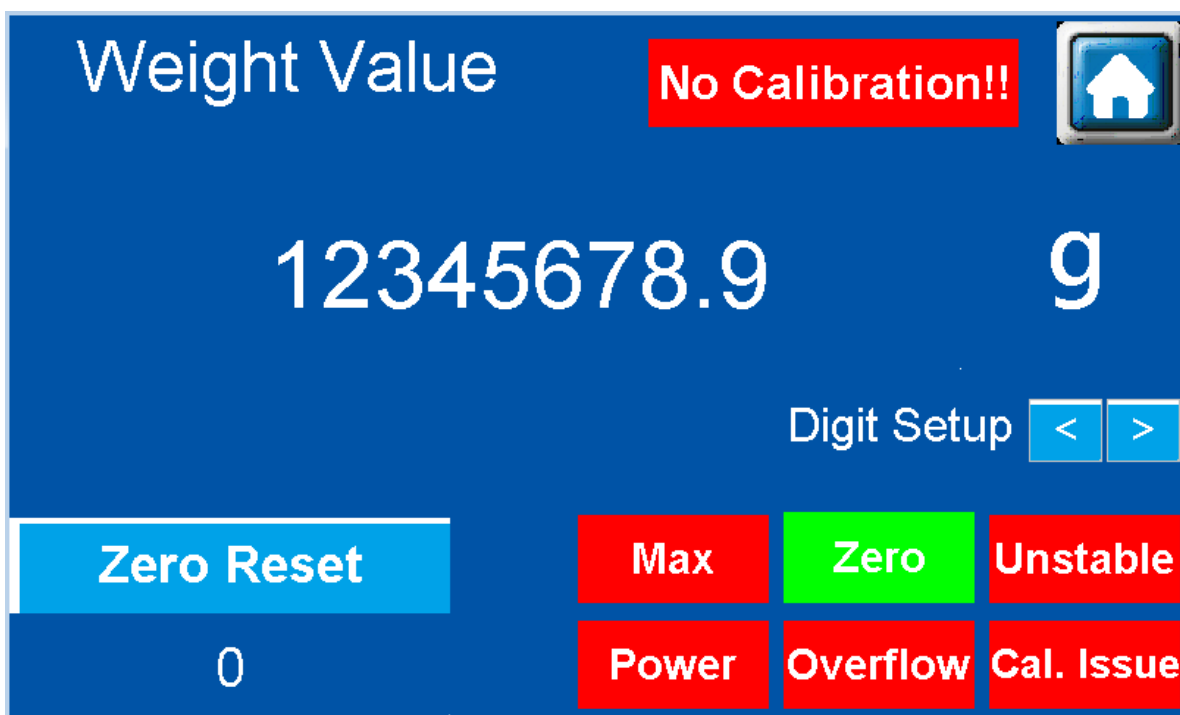

(1) No Calibration

If the calibration is not complete before you enter **Load Cell Full Screen Display** page, a warning **No Calibration!!** appears in the upper right corner, as the image shown below. When this warning appears, the weight value is not reliable. After the calibration is complete, this warning disappears.

No Calibration!!

(2) Zero

When zero calibration is complete and no-load zero reading is stable, the **Zero** in the bulletin is highlighted in a green block.

Zero

(3) Unstable

When the weight value is not stable, the **Unstable** in the bulletin is highlighted in a red block. When the weight value is stable, the **Motion** in the bulletin is highlighted in a green block.



(4) Cal. Issue

When an error occurs, for example, putting a higher value for a lighter weight, even if the calibration is done, the **Cal. Issue** in the bulletin is highlighted in a red block. When this warning appears, the weight value is not reliable.



(5) Overflow

After calculation, the load weight on the weighing platform converts to a digital value. If the digital value exceeds the maximum allowable number, the **Overflow** in the bulletin is highlighted in a red block.



(6) Max

You can set up a weight maximum limit in the Load Cell Setup page. When the weight used exceeds the maximum limit, the **Max** in the bulletin is highlighted in a red block.



(7) Power

When the power supply is abnormal, the **Power** in the bulletin is highlighted in a red block.



(8) Zero Reset

Reset the present value to zero.



(9) Unit Setup

Here you can select the weight unit, in kilogram or in gram.



(10) Digit Setup

Up to 10 digits (integers) to the left of the decimal point can be shown but only 1 digit to the right of the decimal point can be displayed. Use the directional arrows to define how many digits (integers) to the left of the decimal points to be shown.

**3.1.4 Analog I/O**

Press **Analog I/O** from the main setting menu to display its corresponding setting page.

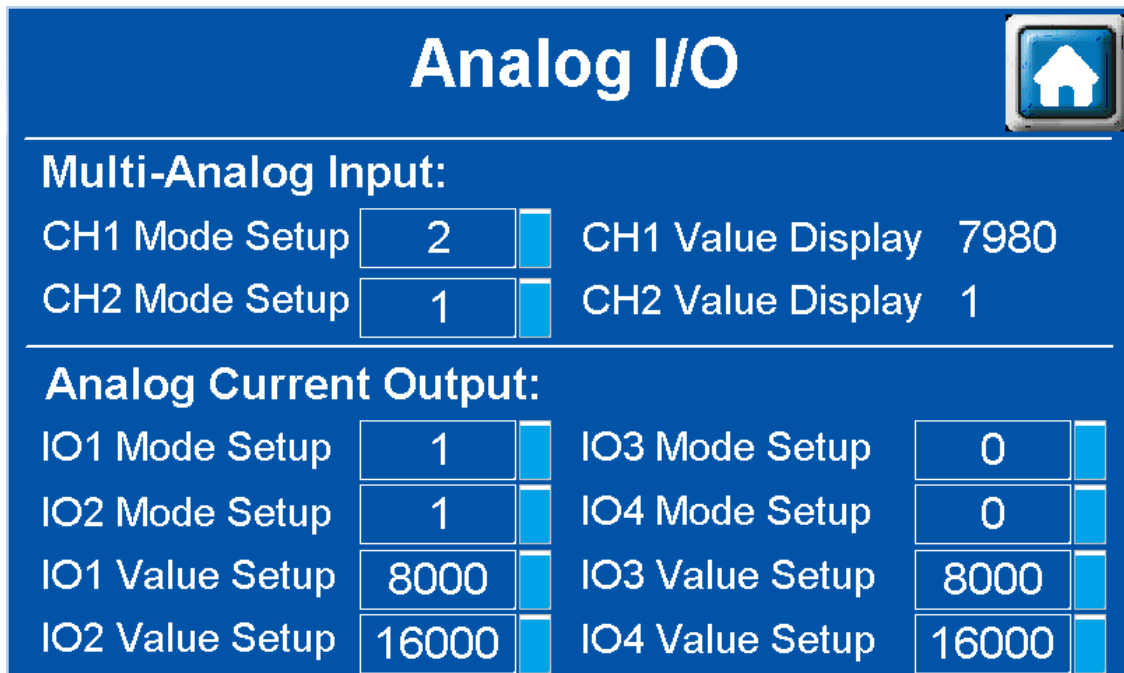

TP70P-211LC1T is with two-channels of multi-analog inputs and four-channels of analog current outputs. You can set up different modes for each channel, read input values and set up output values under this setting item. You can perform basic operations including system adjustments and checks before you have your own programs ready.

Descriptions on the multi-analog inputs and analog current outputs:**Multi-analog inputs****(1) Setting up the channel mode**

Channel Mode	-1	0 (default)	1	2	3
Description	channel closed	0 ~ 5 V	0 ~ 10 V	0 ~ 20 mA	4 ~ 20 mA
Channel Mode	4	5	6	7	21
Description	4 ~ 50 mV	Pt100 sensor	JPt100 sensor	Pt1000 sensor	Cu50 sensor
Channel Mode	22	23	24	25	
Description	Cu100 sensor	Ni100 sensor	Ni1000 sensor	LG-Ni1000 sensor	

(2) Reading channel input values

Read the input values (16-bit) from the corresponding channels; the maximum allowable number to be read is 32000. As the example shown above IO1 outputs the value to CH1. The output value of IO1 should be close to the input value of CH1.

When setting the mode of CH2 to 1, it is 0 ~ 10 V, and if there is no input voltage, the input value should be close to 0.

Analog current outputs

(1) Setting up the channel mode

Channel Mode	0 (default)	1
Description	4 ~ 20 mA	0 ~ 20 mA

(2) Setting up the value to output

The value to output should be in the range of 0 to 32000 for each channel. The value 0 corresponds to the minimum value of the mode set and the value 32000 corresponds to the maximum value of the mode set. See the following examples for reference.

IO1: set the mode to 1, it is 0 ~ 20 mA and when the output value is 8000, the output current is 5 mA.

IO2: set the mode to 1, it is 0 ~ 20 mA and when the output value is 16000, the output current is 10 mA.

IO3: set the mode to 0, it is 4 ~ 20 mA and when the output value is 8000, the output current is 8 mA.

IO4: set the mode to 0, it is 4 ~ 20 mA and when the output value is 16000, the output current is 12 mA.

3.1.5 Digital I/O

Press **Digital I/O** from the main setting menu to display its corresponding setting page.

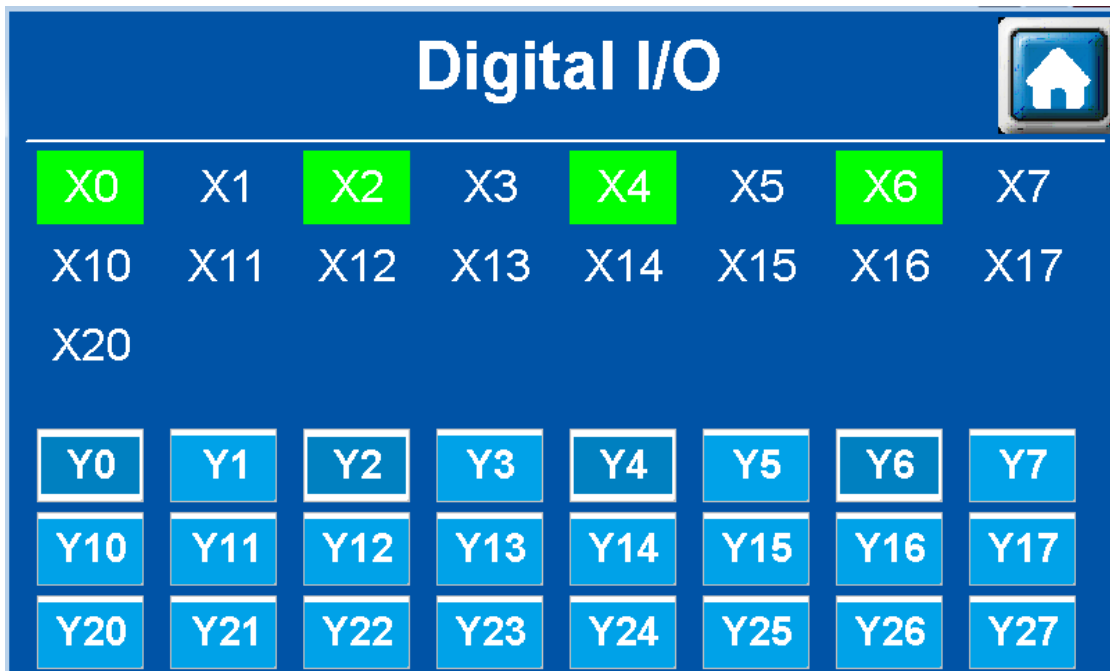

TP70P-211LC1T is with 17 digital inputs and 24 digital outputs. When an input point detects a signal, its corresponding input point in the bulletin is highlighted in a green block. The output points Y0-Y27 can be pressed to send signal to its corresponding devices. The example image shown above uses Y0, Y2, Y4, and Y6 to send signals and once X0, X2, X4 and X6 detect signals, the corresponding input points in the bulletin are highlighted in green blocks.

3.1.6 System Setup

Press **System Setup** from the main setting menu to display its corresponding setting page. You can also press the **RESET** button or use M1662 (refer to section 5.3 for more details) to enter the **System Setup** page. All the TP70P series shares the same System Setups. You can set up the buzzer, real time clock (RTC), the percentage of the backlit brightness, how long the brightness dims out, and many more.

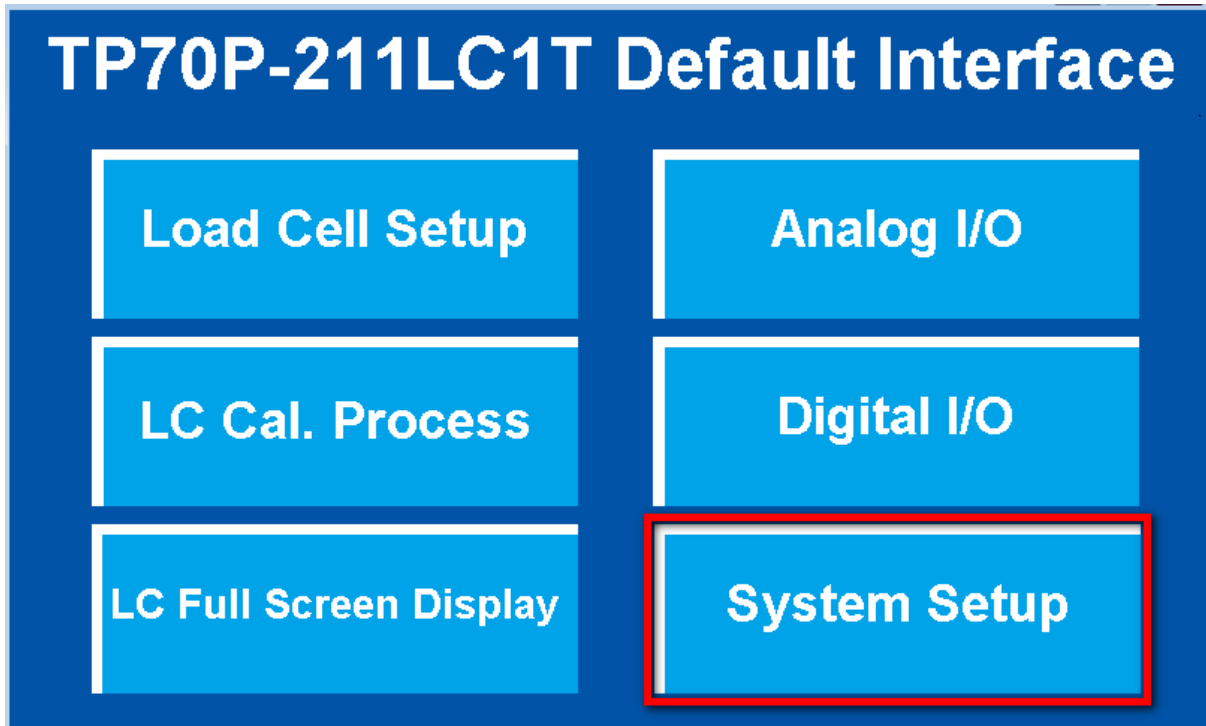

3.2 TP04P-20EXL1T Operational Interface

The default operational interface is as the image shown below; you can download the program in Delta's official website:

<http://www.deltaww.com/>

Load Cell related functions are described below.



1. Load cell Setup



TP04P-20EXL1T is a one-channel load cell with multiple functions. You can use its friendly interface to set up the setting items including excitation voltage, eigenvalue mode, response time mode and configure the parameters for load cell related functions.

2. LoadCell Cal. Process

Before using load cell related functions, you need to calibrate TP04P-20EXL1T to ensure the measurements are going to be accurate. Without other software or programs, you can use the **LC Cal. Process** function on the main setting menu to complete the calibration.

3. Load Cell Measure



Here you can find different kinds of weight values. You can select weight units between kilogram and gram, reset the values to zero and many more.

4. Use    to enter the setting pages of **Load Cell Setup**, **LoadCell Cal. Process**, **Load Cell Measure**.

5. Use  to enter the value setting mode.

6. Use  and  to set up the parameters.

7. Use  to save the setting and go to the next item. Use  to cancel without saving and leave the setting mode.

8. Use  to go back to the main setting menu and use  to go to the next page.

Note: The keys  and  are of no use for this series.

3.2.1 Load Cell Setup

Press the key  to display the corresponding setting page of the **Load Cell Setup**.

There are 10 setting items for you to set up.

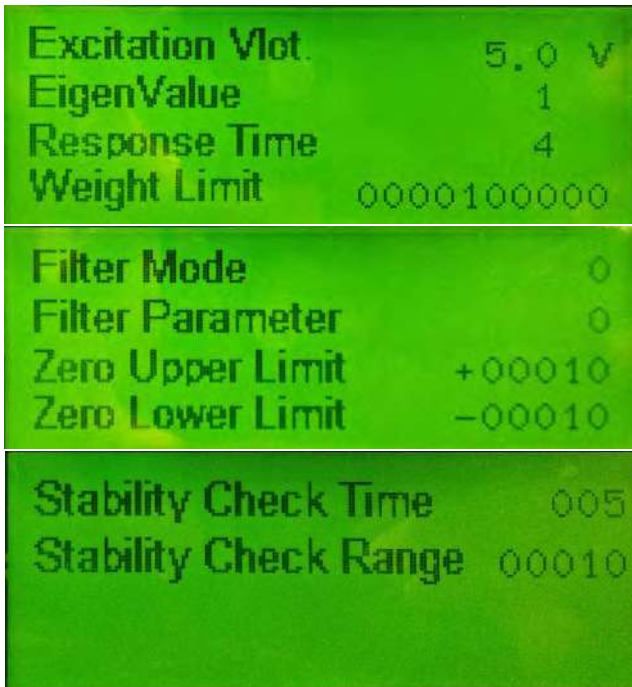

- (1) **Excitation Voltage:** set up the excitation voltage at the load cell, ranging from 2.0 V to 9.5 V.
- (2) **Eigenvalue Mode:** set up the eigenvalue mode from 0 to 9; the excitation voltage in different eigenvalue modes corresponds to different eigenvalues. See the table below for reference.

Excitation voltage	Eigenvalue modes	Eigenvalue (mV/V)	Excitation voltage	Eigenvalue modes	Eigenvalue (mV/V)	Excitation voltage	Eigenvalue modes	Eigenvalue (mV/V)	Excitation voltage	Eigenvalue modes	Eigenvalue (mV/V)
9.5	0	0.5	8.0	0	0.5	6.0	0	0.5	3.5	0	0.5
	1	1		1	1		1	1			
	2	2		2	2		2	2			
	3	3		3	4		3	4			
	4	4		4	8		4	8			
	5	6		5	16		5	16			
	6	7		6	32		6	32			
	7	10		7	50		7	64			
	8	12		8	75		8	128			
	9	16	9	100	9	256					
9.0	0	0.5	7.0	0	0.5	5.0	0	0.5	2.0	0	0.5
	1	1		1	1		1	1			
	2	2		2	2		2	2			
	3	4		3	4		3	4			
	4	8		4	8		4	8			
	5	12		5	16		5	16			
	6	16		6	32		6	32			
	7	24		7	64		7	64			

	8	32		8	128		8	128		8	128
	9	48		9	200		9	256		9	256

(3) **Response Time Mode:** setting range is from 0 to 8; see the modes and their corresponding response times below.

Response time mode	0	1	2	3	4	5	5	7	8
Response time (ms)	2.5	10	16	20	50	60	100	200	400

(4) **Weight Limit:** setting range is from 0 to 2³² (32-bit value); if the value set is out of range, the system sends out an status code.

(5) **Filter Mode:** setting range is from 0 to 2; see the modes and their descriptions below.

Filter Mode	0	1	2
Description	No filter	Maximum value filter	Average value filter

(6) **Filter Parameter:** setting range is from 0 to 8. The bigger the value is set, the more frequent and stronger the filtering is in the maximum value filter mode.

(7) **Upper Zero Limit:** setting range is from 0 to 32767 (16-bit value); zero upper limit is defined here.

(8) **Lower Zero Limit:** setting range is from -1 to -32768; zero lower limit is defined here.

(9) **Stability Checking Times:** setting range is from 1 to 500; the system checks if the value is within its setting range for a number of times that is set here.

(10) **Stability Checking Range:** setting range is from 1 to 1000; the system checks if the value is within its range (±1 to ±1000) that is set here.

3

3.2.2 Load Cell Calibration Process

Press the key **1** to display the corresponding setting page of the **Load Cell Calibration Process**.

(1) Start Cal.

Press **1** to enter the calibration mode. Once **1** is pressed, **Start** will be shown instead of **Finish** as the image shown below. This indicates it is in the calibration mode.



(2) Cal. Number Setup

Press **F** to enter the setting mode of **Cal. Number Setup**. In the setting item **2. Cal. Number Setup**, you can set up a maximum of 20 points for calibration. Use the numerical keys 0-9 to set up a number of points for calibration.

Use **ENT** to save the setting and go to the next item. Use **ESC** to cancel without saving and leave the setting mode.

Use **←** to go back to the main setting menu and use **→** to go to the next page. The example below shows that 2-points setting is set for calibration.



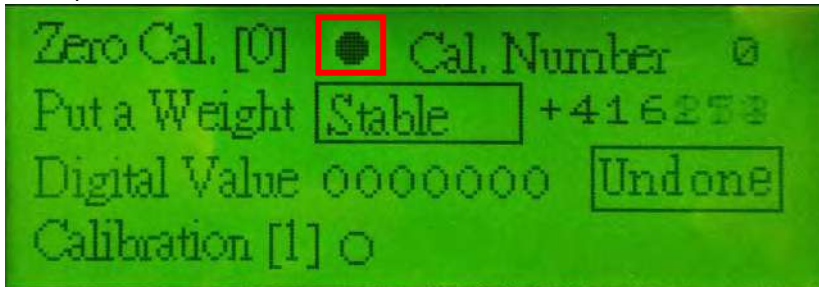

(3) Zero Cal.

Before performing zero calibration, the system checks if the environment is stable. When it is stable, the status besides **Put a Weight** shows **Stable** instead of **Unstable** as the image shown below. Press  to start calibration. When the circle besides **Zero Cal.** becomes a dot as the image shown below, it indicates the calibration is complete.

**(4) Put a Weight**

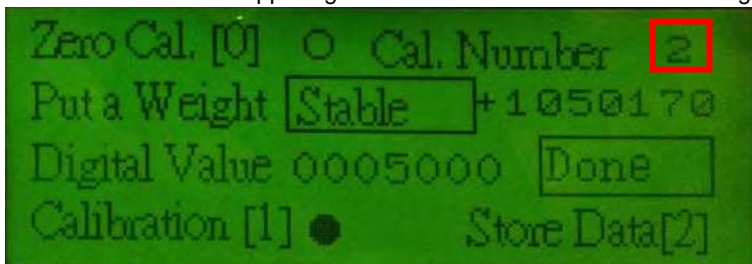
After zero calibration is complete, the number 2 is the next to be calibrated, see the image below for reference; the **Cal. Number** is in the upper right corner. You can use a standard weight for calibration.

**(5) Digital Value :**

Put an object that you know its weight on the load cell sensor and use  to enter the setting mode and then use numerical keys 0-9 to enter its digital value for calibration. Use  to save the setting and go to the next item. The image below shows an example of using a 100g weight for calibration. Enter the digital value 1000 in the field of **Digital Value Setup**. After the value is settled, the status shows **Stable** and then you can start calibration.

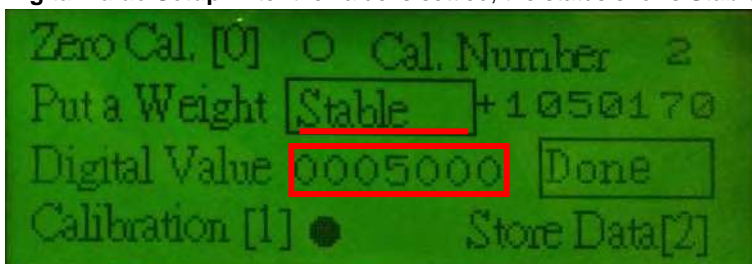
**(6) Calibration [1] :**

The **Stable** shown in the upper right corner indicates the value is settled. Press  to calibrate the number 1 (shown as number 0 on the screen). When the circle besides **Calibration [1]** becomes a dot as the image shown below, it indicates the calibration is complete.

If the number 0 (shown as number 0 on the screen) is not the final point set for calibration, the next number appears for calibration. Repeat steps (4) - (6) to complete calibration for all the points. The example below shows that 2-points setting is set for calibration. Thus the number 2 appears for calibration. The image below shows an example of using a 200g weight for calibration. Enter the digital value 2000 in the field of **Digital Value Setup**. After the value is settled, the status shows **Stable** and then press the **Calibration** button to complete the calibration for the number 2.

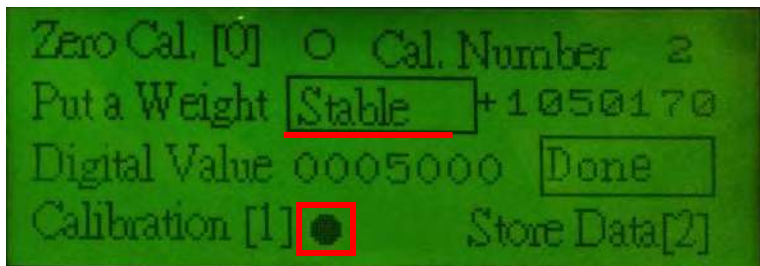

- (7) After all calibrations are complete, the **Undone** changes to **Done** and **Store Data [2]** is shown in the lower right corner, as the image shown below. Press to save the settings. Otherwise, the changes will not be saved.

3

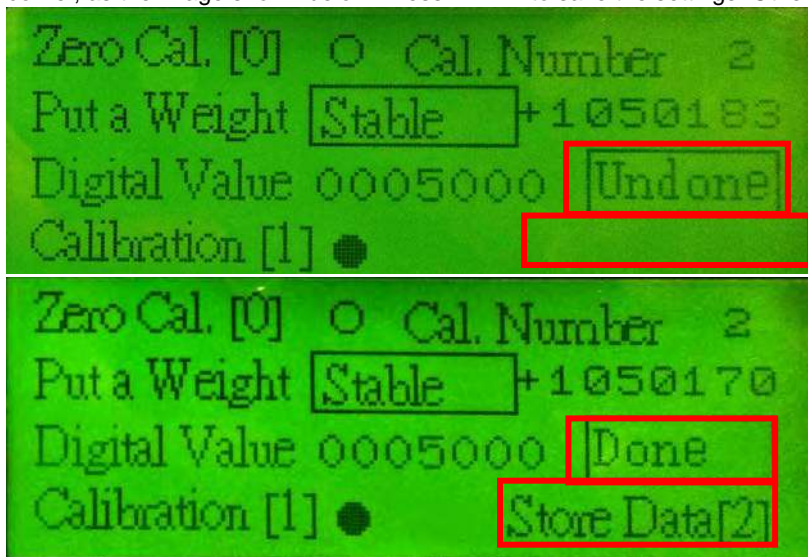

Use to go back to the main setting menu and you can see the status shown is **Finish** as the image shown below. This indicates the calibration is complete.



You can reset all the settings to default. Use in the main setting menu to go back to defaults.

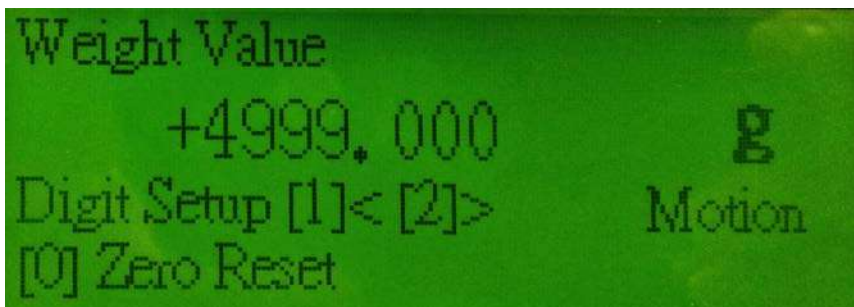
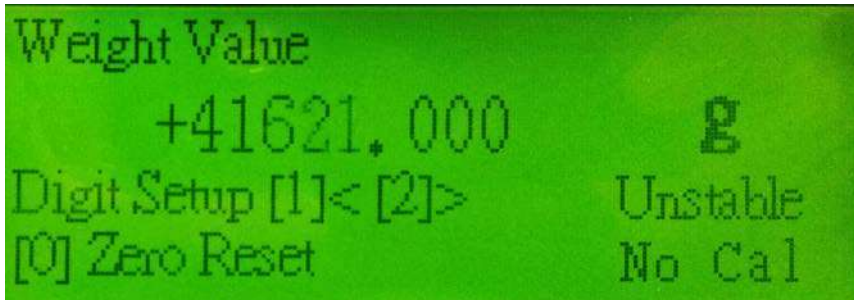

3.2.3 Load Cell Measure

Press the key  to display the corresponding setting page of the **Load Cell Measure**.



Use  to show less information as the image shown below. Use  to go back.



(1) No Calibration

If the calibration is not complete before you enter **Load Cell Measure** page, a warning **No Cal** appears in the lower right corner, as the image shown above. When this warning appears, the weight value is not reliable. After the calibration is complete, this warning disappears.

(2) Zero

When zero calibration is complete and no-load zero reading is stable, the **Zero** is shown.

(3) Unstable

When the weight value is not stable, the **Unstable** appears. When the weight value is stable, the **Motion** is shown.

(4) Max

You can set up a weight maximum limit in the Load Cell Setup page. When the weight used exceeds the maximum limit, the **Max** appears.



(5) Zero Reset

Press  to reset the present value to zero.

(6) Unit Setup

Press  to select the weight unit, in kilogram or in gram.

(7) Digit Setup

Up to 10 digits (integers) to the left of the decimal point can be shown but only 3 digits to the right of the decimal point can be displayed. Use   to define how many digits (integers) to the left of the decimal points to be shown.



Chapter 4 Installation and Wiring

Table of Contents

- 4.1 Installation..... 4-2**
- 4.2 Wiring 4-3**
 - 4.2.1 Wiring Power..... 4-3
 - 4.2.2 Wiring Digital Input Terminals..... 4-5
 - 4.2.3 Wiring Digital Output Terminals 4-5
 - 4.2.4 Wiring Analog Input Terminals 4-6
 - 4.2.5 Wiring Analog Voltage / Current Output Terminals 4-7
 - 4.2.6 Wiring Analog Current Output Terminals 4-8
 - 4.2.7 Mixed Analog Input Terminals..... 4-9
 - 4.2.8 Wiring Load Cell Terminals 4-10
 - 4.2.9 Definitions of RS-485 Ports 4-11

4.1 Installation

Install TP70P-211LC1T / TP04P-20EXL1T in a control panel. Put TP70P-211LC1T / TP04P-20EXL1T into the control panel and use the enclosed fasteners and screws for a more secured installation. The required torque for tightening a screw should be less than 2.75 kg-cm; do NOT exceed 2.75 kg-cm to avoid damaging the panel. TP70P-211LC1T / TP04P-20EXL1T is water resistant to IP66 / NEMA4 standard but Delta Electronics warranty does NOT cover if the installation is NOT correctly complete. The control panel should be IP rated to IP66 / NEMA4 to meet the requirement of no ingress of dust and water.

Follow the storage suggestions below.

1. Do NOT install TP70P-211LC1T and TP04P-20EXL1T in a location subjected to airborne dust, metallic particles, oil smoke, or corrosive / flammable gases.
2. Do NOT install TP70P-211LC1T and TP04P-20EXL1T in high-temperature, relative humid or condensing location.
3. Install TP70P-211LC1T and TP04P-20EXL1T on a solid and durable surface to avoid shocks or vibrations.

4

● **TP70P-211LC1T**

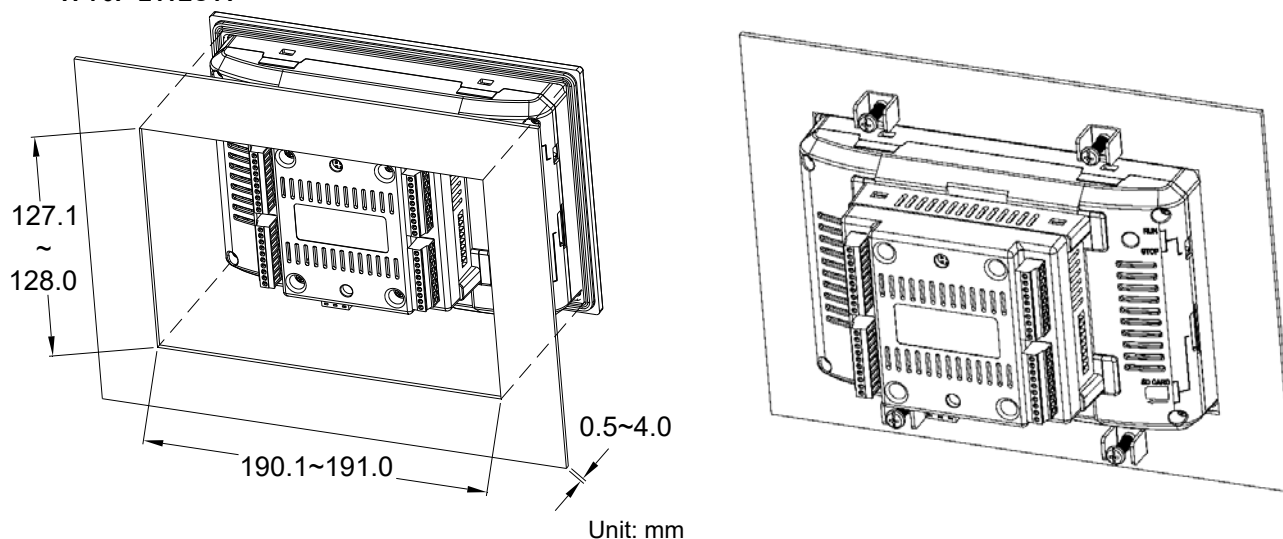

● **TP04P-20EXL1T**

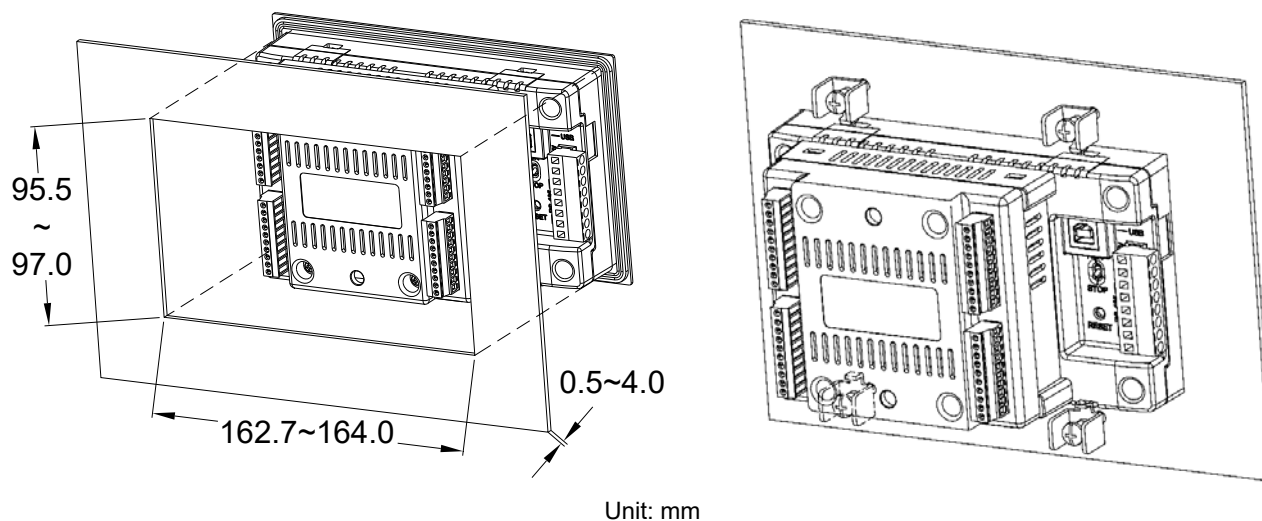

4.2 Wiring

● Wiring Precautions

1. For input and output terminals, use single-core cables or twin-core cables in a diameter of 22 AWG–16 AWG with pin-type connectors smaller than 1.5 mm. Use only copper conducting wires that can resist temperatures above 60° C–75° C. The required torque for tightening a terminal screw should be less than 1.90 kg-cm (1.65 lb-in).

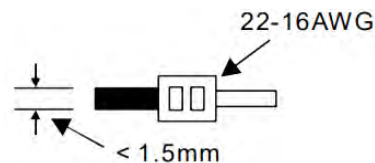

2. For power terminals, use single-core cables or twin-core cables in a diameter of 12 AWG–22 AWG. Use only copper conducting wires that can resist temperatures above 60° C–75° C. The required torque for tightening a PLC terminal screw should be less than 5–8 kg-cm (4.3–6.9 lb-in).
3. Do NOT wire empty terminals.
4. To prevent a surge and induction, the cable and the input signal cables that are connected to the TP70P-211LC1T / TP04P-20EXL1T must be separate cables.
5. Prevent foreign objects, such as oil, water, or metal powder entering TP70P-211LC1T / TP04P-20EXL1T through the ventilation holes. Prevent drill shavings or other debris entering TP70P-211LC1T / TP04P-20EXL1T.
6. To increase the cooling efficiency, install TP70P-211LC1T / TP04P-20EXL1T with sufficient space between adjacent objects and walls to prevent poor heat dissipation.

4.2.1 Wiring Power

Use DC power supply for TP70P-211LC1T and TP04P-20EXL1T and note the followings.

1. Connect to the terminal ends 24 VDC and 0 V. The power supplied to TP70P-211LC1T and TP04P-20EXL1T should be within the range of 20.4 to 28.8 VDC. If the power supplied is lower than 20.4 VDC, TP70P-211LC1T and TP04P-20EXL1T may stop working and all outputs may be OFF.
2. When the power is cut, TP70P-211LC1T and TP04P-20EXL1T still can work for up to 10 milliseconds. However, if the power is cut for longer than 10 milliseconds, TP70P-211LC1T and TP04P-20EXL1T may stop working and all outputs may be OFF. After the power is restored, TP70P-211LC1T and TP04P-20EXL1T resume to work. TP70P-211LC1T and TP04P-20EXL1T are featured with latching auxiliary relays and retentive registers. You can take advantage of this feature while programming.

3. Only DC power supply can be used for TP70P-211LC1T and TP04P-20EXL1T. You can use Delta power supply modules such as DVPPS01, DVPPS02, and DVPPS05 to supply DC power for TP70P-211LC1T and TP04P-20EXL1T. Refer to the following for a better protected circuit for DVPPS01, DVPPS02, and DVPPS05.

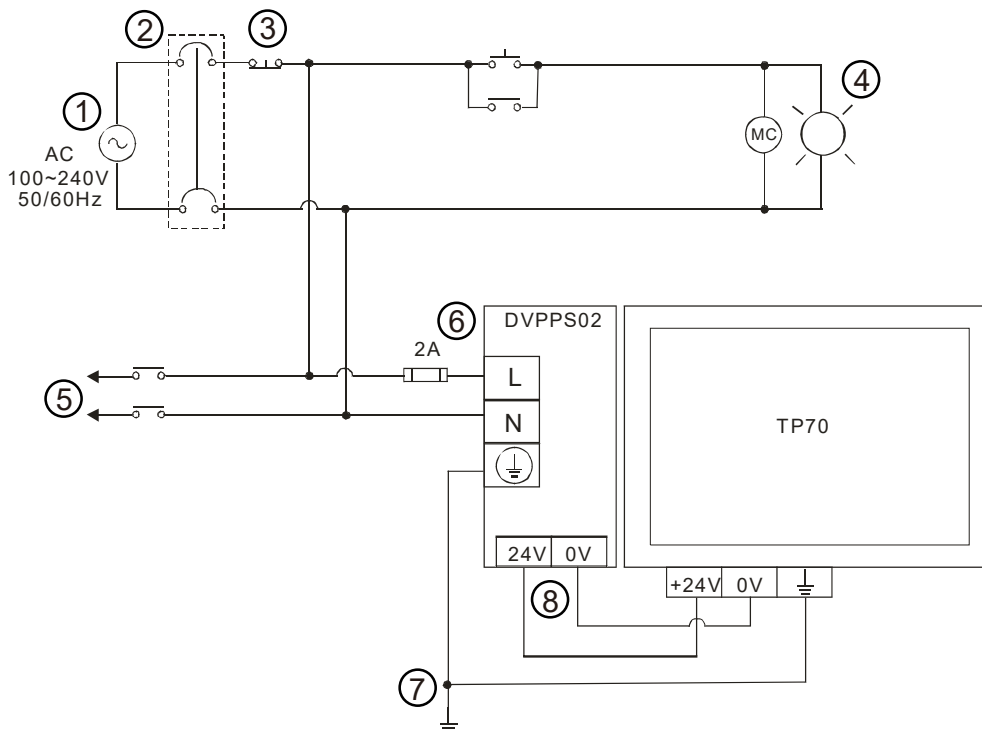

4

①	AC power supply: 100 ~ 240 VAC, 50/60 Hz
②	Circuit breaker
③	Emergency stop button: used to cut power off when an emergency occurs
④	Power indicator
⑤	AC load
⑥	2 A fuse
⑦	Ground (impedance: below 100 Ω)
⑧	DC power supply: 24 VDC

4.2.2 Wiring Digital Input Terminals

The input signal is DC power input. Sinking and sourcing are the current driving capabilities of a circuit.

- **Sinking**

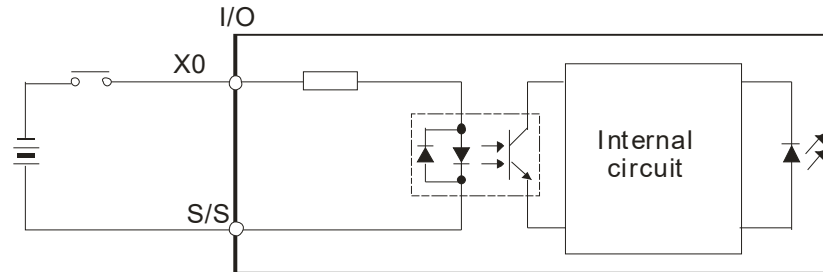

- **Sourcing**

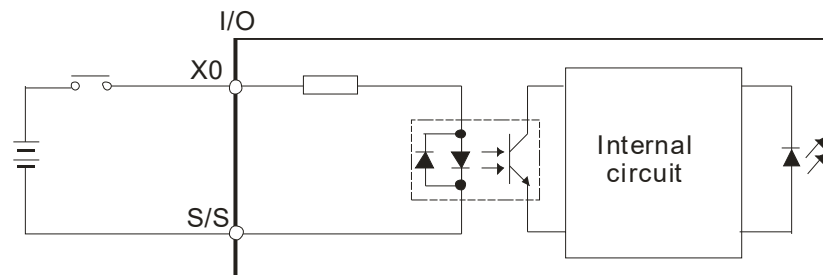

4.2.3 Wiring Digital Output Terminals

Transistor output

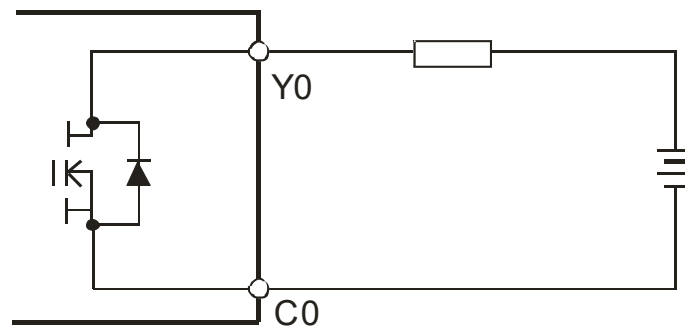

4.2.4 Wiring Analog Input Terminals

- Only TP04P-20EXL1T has this feature analog voltage / current input in a range of V0+ ~ V3+.
- TP70P-211LC1T does NOT include this feature.

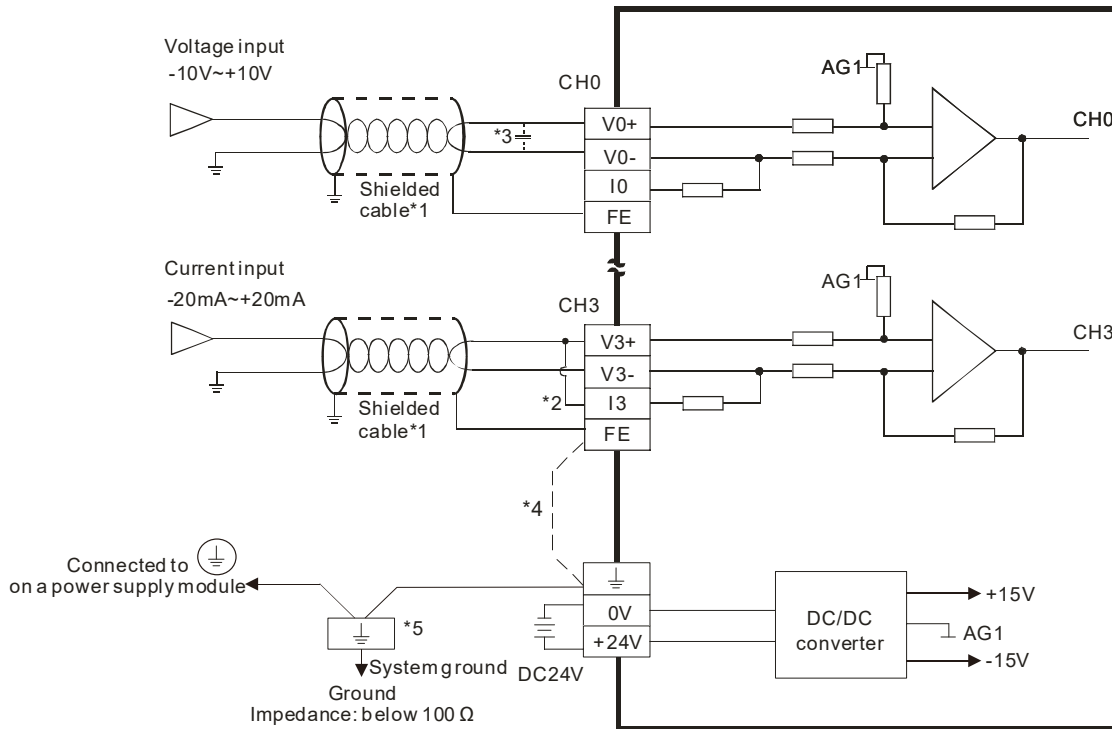

- *1. Use shielded cables to isolate the analog input signal cable from other power cables.
- *2. If the module is connected to a current signal, the terminals V3+ and I3 must be short-circuited.
- *3. If variability in the input voltage results in interference within the wiring, connect the module to a capacitor with a capacitance between 0.1–0.47 μF and a working voltage of 25 V.
- *4. To prevent too much noise and interference, connect the FE of the shielded cable to ground.
- *5. Connect the ground terminal of a power supply module and the analog input terminal FE to the system ground and then ground the system ground or connect the system ground to a distribution box

4.2.5 Wiring Analog Voltage / Current Output Terminals

- Only TP04P-20EXL1T has this feature analog voltage / current input in a range of V4 ~ V5.
- TP70P-211LC1T does NOT include this feature.

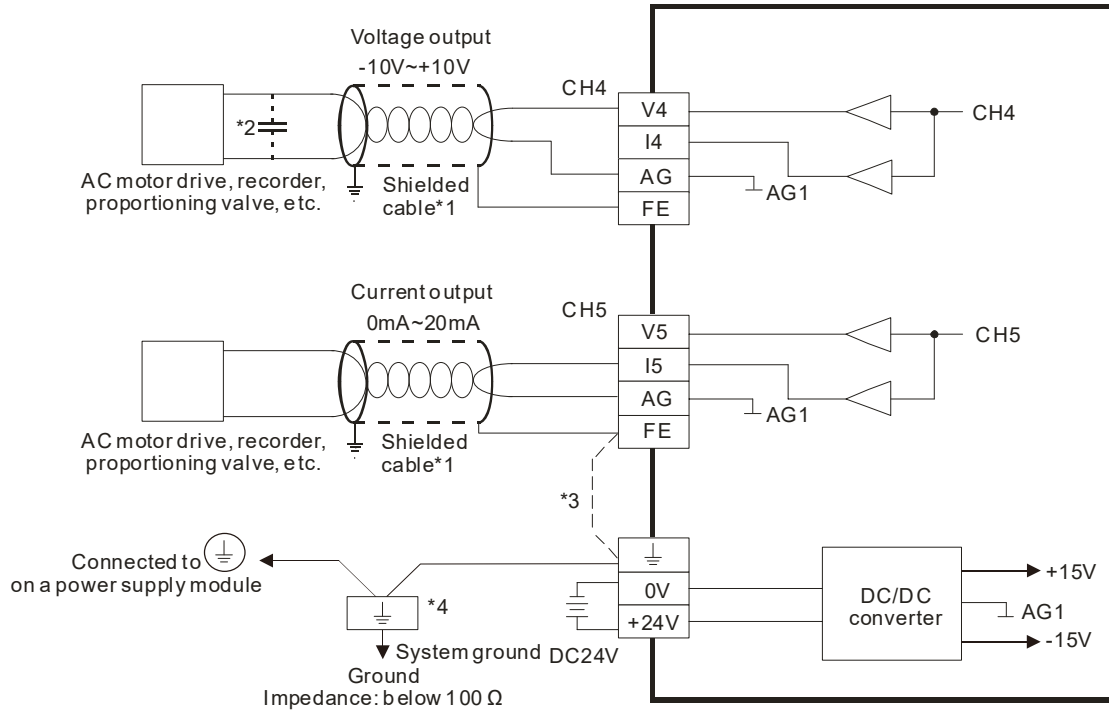

*1. Use shielded cables to isolate the analog input signal cable from other power cables.

*2. If variability in the input voltage results in interference within the wiring, connect the module to a capacitor with a capacitance between 0.1–0.47 μF and a working voltage of 25 V.

*3. To prevent too much noise and interference, connect the FE of the shielded cable to ground.

*4. Connect the ground terminal of a power supply module and the analog input terminal FE to the system ground and then ground the system ground or connect the system ground to a distribution box

4.2.6 Wiring Analog Current Output Terminals

- The IO1 ~ IO4 of TP04P-20EXL1T and TP70P-211LC1T are for analog current outputs only, NOT for analog voltage outputs.

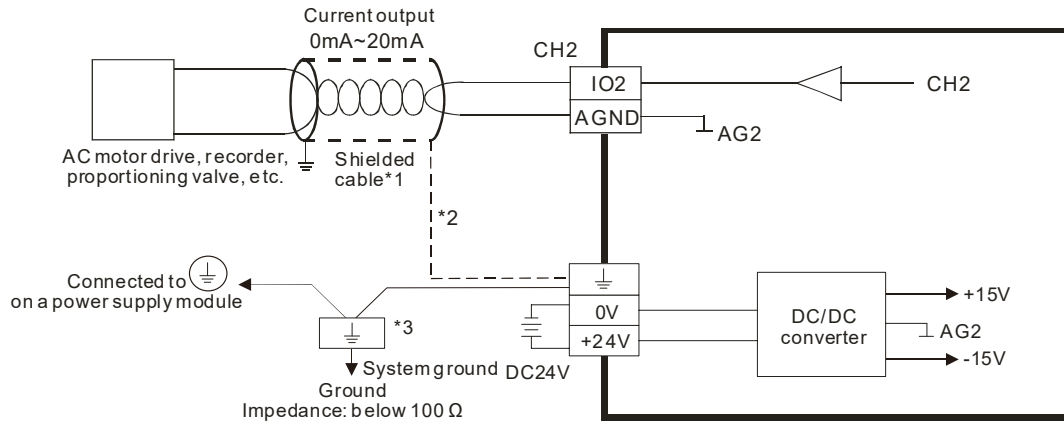

- *1. Use shielded cables to isolate the analog input signal cable from other power cables.
- *2. To prevent too much noise and interference, connect the FE of the shielded cable to ground.
- *3. Connect the ground terminal of a power supply module and the analog input terminal FE to the system ground and then ground the system ground or connect the system ground to a distribution box

4.2.7 Mixed Analog Input Terminals

- Temperature Measurement Input Terminals

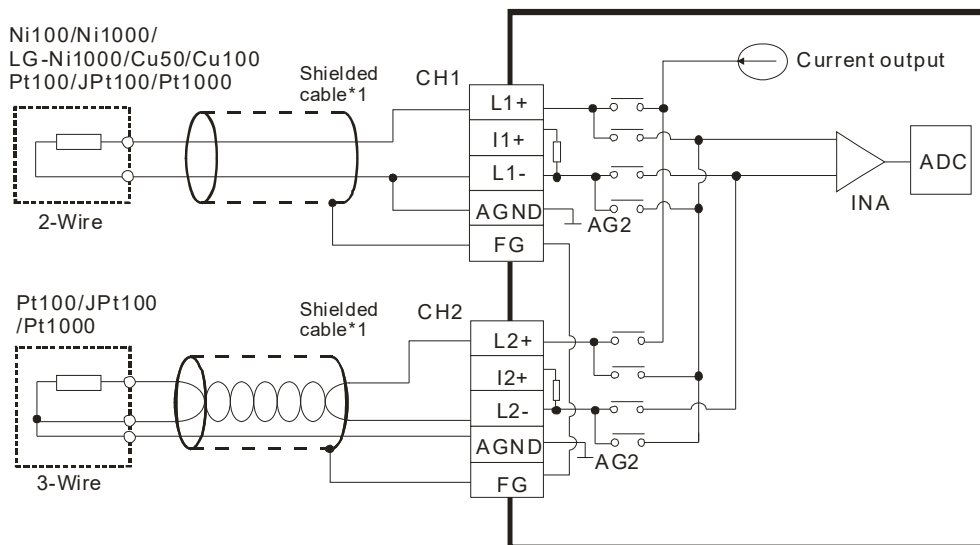

*1. Use shielded cables to isolate the analog input signal cable from other power cables.

- Voltage / Current Input Terminals

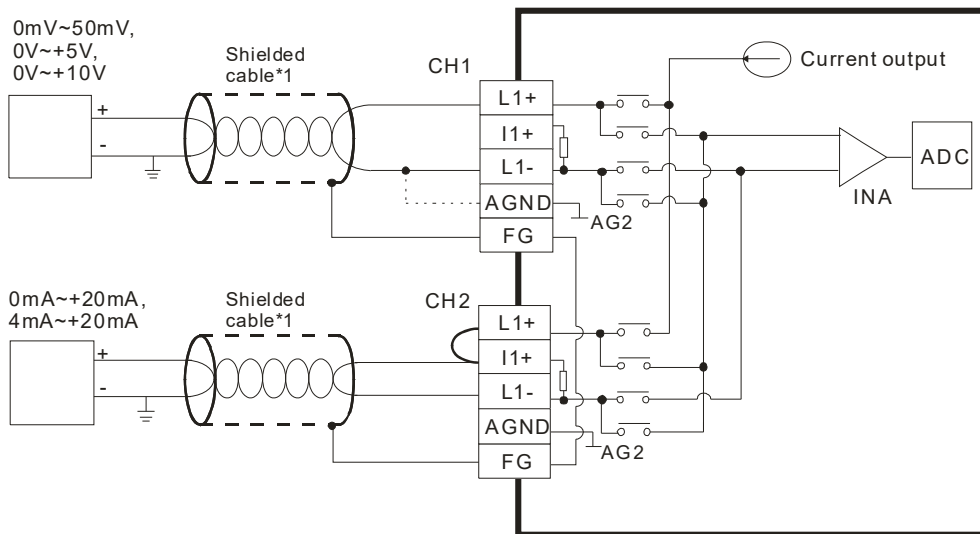

*1. Use shielded cables to isolate the analog input signal cable from other power cables.

4.2.8 Wiring Load Cell Terminals

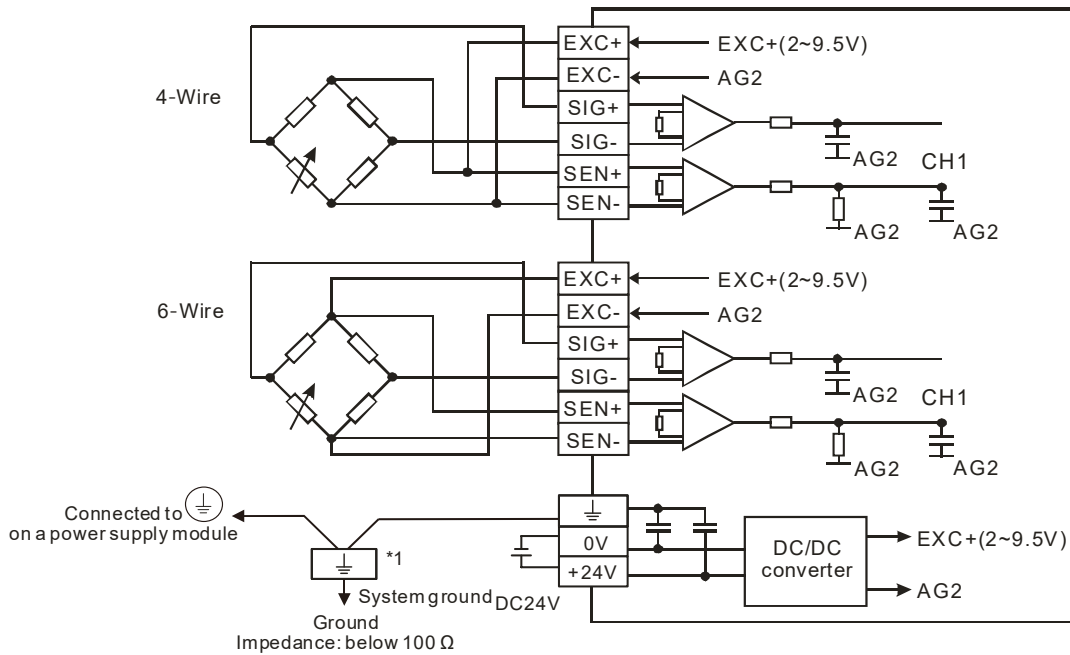

*1. Connect the \perp of a power supply module and the \perp of the load cell terminal FE to the system ground and then ground the system ground or connect the system ground to a distribution box

*2. While connecting multiple load cell modules, the total impedance of the load cell modules should be greater than 40 Ω.

● Selecting a Load Cell Sensor

1. Excitation Voltage / Sensibility (V)

An excitation voltage is the power provided externally for a load cell sensor. The voltage stated in the specification is the maximum voltage that a sensor can take. The excitation voltage that a load cell module provides is +2 ~ 9.5 V, and therefore the voltage between +2 ~ 9.5 V is what a sensor can take as its excitation voltage.

2. Eigenvalue

A load cell is based on an electrical circuit called Wheatstone bridge. When a sensor whose resistance varies with applied force, this small resistance change is magnified by the resistive imbalance produced in the Wheatstone bridge and thus obtains an output signal proportional SIG+/SIG- to the applied force. The resistive circuit is proportional to the input voltage supply, and the output of the load cell is often expressed in mV/V, milivolts per volt (supply). Eigenvalue is a characteristic value for a load cell. The excitation voltage in different eigenvalue modes corresponds to different eigenvalues. The supported excitation voltage range is 0.5 ~ 256 mV/V. Refer to section 3.1.1 for more details. Any sensor with up to 256 mV/V of excitation voltage can be used.

The output equation is (applied force divided by maximum rated load) multiples (excitation voltage multiples eigenvalue).

Example:

Output voltage: 1 mV, Applied force: unknown, Maximum rated load: 10 kg, Excitation voltage: 5 V,

Eigenvalue: 2 mV/V

The equation is $1 \text{ mV} = (\text{unknown applied force} / 10 \text{ kg}) * (5 \text{ V} * 2 \text{ mV/V})$

The result: the applied force is 1 kg.

3. Maximum rated load

When selecting a load cell module, you need to check its specifications, such as the maximum rated load, tares, vibrations, shocks and so on. The closer the on a load cell sensor is to the maximum rated load specified for the load cell sensor, the more accurate the measurement is.

4. Four-Wire or Six-Wire

You can use 4-wire or 6-wire method for wiring a load cell sensor. Select the 4-wire method when the distance of the connected terminal between a module and a sensor is smaller or select the 6-wire method when the distance of the connected terminal between a module and a sensor is larger. A load cell module provides power (excitation voltage EXC+/EXC-) to a load cell sensor. When there is impedance between a load cell module and a sensor, the excitation voltage that a sensor received is usually less than the excitation voltage that a module sent. The output signal SIG+/SIG- and the excitation voltage EXC+/EXC- are related; if the distance between a module and a sensor is smaller, the impedance between the module and the sensor is also lesser.

5. Precision

The precision of a load cell module is the result of the maximum rated load multiples 0.01%. The precision of the load cell module is 0.01%. But lots of factors can affect the precision; for instance if the differential error is too big or the precision is too low or the influences of vibrations or shocks occur in the environment, and then the precision 0.01% is hard to maintain. You can set the mode to a longer response time mode to have a more stable weight value and thus increase the precision. Refer to section 3.1.1 for more details on the response time modes. When selecting a load cell module, you can check the specifications of the response time mode and the precision to see if they meet your requirements.

4.2.9 Definitions of RS-485 Ports

● TP70P-211LC1T

Pin	RS-485 (COM2) -for PLC mode	RS-485 (COM3) -for TP mode
5	GND	GND
6	D+	N/C
7	D-	N/C
8	N/C	D+
9	N/C	D-

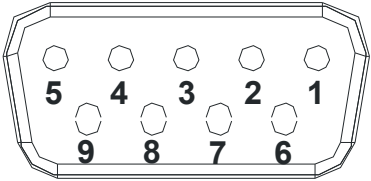

● **TP04P-20EXL1T**

You can find the definitions of RS-485 ports on the product case as the image shown below, D1+, D1-, D2+, D2- and SG. D1+ and D1- are for PLC Mode while D2+ and D2- are for TP Mode.

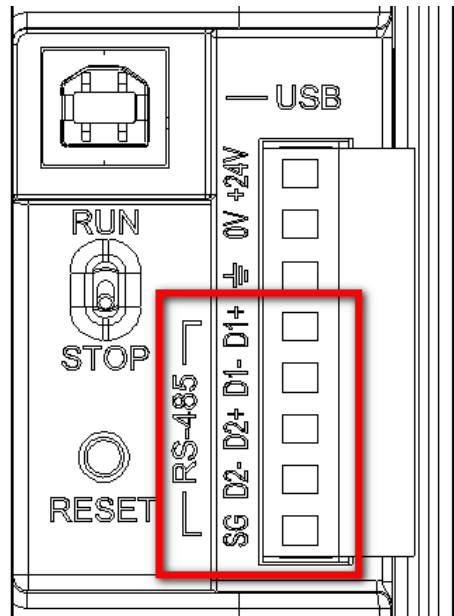

4

Chapter 5 Devices



Table of Contents

5.1	Devices	5-2
5.2	Special Data Registers	5-4
5.3	Special Auxiliary Relay	5-12
5.4	Special Data Registers Specific for TP Series	5-21

5.1 Devices

The list is specific for TP70P-211LC1T and TP04P-20EXL1T only.

Item		Description			
Control method		Stored program, cyclic scan system			
I/O processing method		Batch processing method (when END instruction is executed)			
Execution speed		LD instructions at 0.76µs			
Program language		Instruction, Ladder Diagram (LD), Sequential Function Charts (SFC)			
Program capacity		TP70P-211LC1T: 4K Steps TP04P-20EXL1T: 8K Steps			
Relay Bit device	X	External input relay		TP04P-20EXL1T: X0 ~ X7, X10 ~ X17 · X20 TP70P-211LC1T: X0 ~ X7, X20	
	Y	External output relay		TP04P-20EXL1T: Y0 ~ Y7, Y10 ~ Y17, Y20 ~ Y27 TP70P-211LC1T: Y0 ~ Y7, Y20 ~ Y27	
	M	Auxiliary relay	General	M0~M511: 512 auxiliary relays (*1) M768~M999: 232 auxiliary relays (*1) M2000~M2047: 48 auxiliary relays (*1)	4096 auxiliary relays in total
			Latching	M512~M767: 256 auxiliary relays (*2) M2048~M4095: 2048 auxiliary relays (*2)	
			Special	M1000~M1999: 1000 auxiliary relays Some of them are latching auxiliary relays	
	T	Timer	100 ms (If M1028 is ON, T64~T126 will be 10 millisecond timers.)	T0~T126: 127 timers (*1) T128~T183: 56 timers (*1)	256 timers in total
				T184~T199 (for subroutines): 16 timers (*1)	
				T250~T255 (accumulation): 6 timers (*1)	
			10 ms (If M1038 is ON, T200~T245 will be 1 millisecond timers.)	T200~T239: 40 timers (*1)	
	T240~T245 (accumulation), 6 timers (*1)				
C	Counter	1 ms	T127: 1 timer (*1) T246~T249 (accumulation): 4 timers (*1)	140 counters in total	
		16-bit up counter	C0~C111: 112 counters (*1) C128~C199: 72 counters (*1) C112~C127: 16 counters (*2)		
		32-bit up/down counter	C200~C223: 24 counters (*1) C224~C232: 9 counters (*2) C233~C234: 2 counters (*2) C237~C250: 14 counters (*2) C252~C255: 3 counters (*2)		
C	Counter	32-bit high-speed up/down counter	C235, C236: one-phase one-input, 2 counters (*2) C251: two-phase two-input, 1 counter (*2)	3 counters in total	

Item			Description	
S	Stepping relay	Initialization	S0~S9: 10 stepping relays (*2)	
		Returning to zero	S10~S19: 10 stepping relays (used with the IST instruction) (*2)	
		Latching	S20~S127: 108 stepping relays (*2)	
		General	S128~S911: 784 stepping relays (*1)	
		Alarm	S912~S1023: 112 stepping relays (*2)	
			1024 stepping relays in total	
Register Word device	T	Present value in a timer	T0~T255: 256 timers	
	C	Present value in a counter	C0~C199: 200 counters (16-bit), 200 data registers in total	
			C200~C254: 55 counters (32-bit), 55 data registers in total	
	D	Data register	General	D0~D407: 408 data registers (*1) D600~D999: 400 data registers (*1)
			Retentive	D408~D599: 192 data registers (*2) D2000~D3899: 1900 data registers (*2)
			Special	D1000~D1999: 1000 data registers (Some of them are retentive data registers.) D3900~D4299: 400 data registers (*3) D4300~D4999: 700 data registers (*4)
			Index	E0~E7, F0~F7: 16 data registers (*1)
				5000 data registers in total
	Pointer	N	Master control loop	N0~N7: 8 N devices
		P	Pointer	P0~P255: 256 pointers
I		Interrupt	External interrupt	I000/I001(X0), I100/I101(X1) (01: Rising edge-triggered  ; 00: Falling edge-triggered )
			Timer interrupt	N/A
			High-speed interrupt	I010: 1 interrupt
			Communication interrupt	I150 (COM2): 1 interrupt (*3)
Constant		K	Decimal system	K-32,768~K32,767 (16-bit operation) K-2,147,483,648~K2,147,483,647 (32-bit operation)
	H	Hexadecimal system	H0000~HFFFF (16-bit operation) H00000000~HFFFFFFFF (32-bit operation)	
Real time clock (RTC)			Year, Month, Date, Day, Hour, Minute, Second	

Note:

*1: They are not latching/retentive devices. They can not be changed.

*2: They are latching/retentive devices. They can not be changed.

*3: COM2 is RS-485 communication port by default

*4: Special registers specific for TP04P-20EXL1T and TP70P-211LC1T

5.2 Special Data Registers

The types and functions of special data registers (special D) are listed in the table below. Some registers of the same No. may bear different meanings for different PLC series. "R" in the column of Attribute refers to "read only" and "R/W" refers to "read and write"; "-" refers to the status remains unchanged and "#" refers to the setting is based on the PLC setting status.

Special D	Content	OFF ↓ ON	STOP ↓ RUN	RUN ↓ STOP	Attrib.	Latched	Default
D1000	Watchdog timer for program scan timeout (WDT) (unit: ms)	300	-	-	R/W	NO	300
D1001	TP firmware version (for example when the value is HXX10, it indicates the FW version is V1.0)	-	-	-	R	NO	#
D1002	Program capacity TP70P: 4K Steps TP04P: 8K Steps	#	-	-	R	NO	4K / 8K
D1003	Sum of the PLC internal program memory	-	-	-	R	YES	-7920
D1004	Error code for syntax check	0	0	-	R	NO	0
D1008	Step address when WDT is ON	0	-	-	R	NO	0
D1009	Low voltage signal (LV) occurrence	-	-	-	R	YES	0
D1010	Current scan time (Unit: 0.1 ms)	#	#	#	R	NO	0
D1011	Minimum scan time (Unit: 0.1 ms)	#	#	#	R	NO	0
D1012	Maximum scan time (Unit: 0.1 ms)	#	#	#	R	NO	0
D1015	Value of accumulative high-speed timer (0~32,767, unit: 0.1 ms)	0	-	-	R/W	NO	0
D1018	πPI (Low word)	H'0FDB	H'0FDB	H'0FDB	R/W	NO	H'0FDB
D1019	πPI (High word)	H'4049	H'4049	H'4049	R/W	NO	H'4049
D1022	Counting mode selection for AB phase counter	4	-	-	R/W	NO	4
D1025	Code for communication request error	0	-	-	R	NO	0
D1028	Index register E0	0	-	-	R/W	NO	0
D1029	Index register F0	0	-	-	R/W	NO	0
D1038	Response time delay setting when PLC is SLAVE in COM2 (RS-485). Range: 0 ~ 10,000 (unit: 0.1 ms).	-	-	-	R/W	NO	0
	By using PLC LINK in COM2 (RS-485), D1038 can be set to send next communication cycle data with delay. Range: 0 ~ 10,000 (Unit: one scan cycle)						
D1039	Fixed scan time (ms)	0	-	-	R/W	NO	0
D1040	Order of the 1 st Step switching to ON	0	-	-	R	NO	0
D1041	Order of the 2 nd Step switching to ON	0	-	-	R	NO	0
D1042	Order of the 3 rd Step switching to ON	0	-	-	R	NO	0

Special D	Content	OFF ↓ ON	STOP ↓ RUN	RUN ↓ STOP	Attrib.	Latched	Default			
D1043	Order of the 4 th Step switching to ON	0	-	-	R	NO	0			
D1044	Order of the 5 th Step switching to ON	0	-	-	R	NO	0			
D1045	Order of the 6 th Step switching to ON	0	-	-	R	NO	0			
D1046	Order of the 7 th Step switching to ON	0	-	-	R	NO	0			
D1047	Order of the 8 th Step switching to ON	0	-	-	R	NO	0			
D1049	Number of the Alarm switching to ON	0	-	-	R	NO	0			
D1050 ↓ D1055	Convert data for Modbus communication; PLC automatically converts the ASCII data in D1070~D1085 into Hex data and stores the 16-bit Hex data into D1050~D1055	0	-	-	R	NO	0			
D1062	Average of DRV analog input times (TP04P-20EXL1T)	-	-	-	R/W	YES	2			
D1067	Error code for program execution error	0	0	-	R	NO	0			
D1068	Address of program execution error	0	-	-	R	NO	0			
D1070 ↓ D1085	Feedback data (ASCII) of Modbus communication; When PLC's RS-485 communication instruction receives feedback signals, the data will be saved in the registers D1070~D1085. Usres can check the received data in these registers.	0	-	-	R	NO	0			
D1089 ↓ D1099	Sent data of Modbus communication. When PLC's RS-485 communication instruction sends out data, the data will be stored in D1089~D1099. Users can check the sent data in these registers.	0	-	-	R	NO	0			
D1110	Average value of analog input channel 0 (AD 0) When average times in D1062 is set to 1, D1110 indicates present value.	0	-	-	R	NO	#			
D1111	Average value of analog input channel 1 (AD 1) When average times in D1062 is set to 1, D1111 indicates present value	0	-	-	R	NO	#			
D1112	Average value of analog input channel 2 (AD 2) When average times in D1062 is set to 1, D1112 indicates present value	0	-	-	R	NO	#			
D1113	Average value of analog input channel 3 (AD 3) When average times in D1062 is set to 1, D1113 indicates present value	0	-	-	R	NO	#			
D1114	Analog input/output setting mode (TP04P-20EXL1T)				-	-	-	R/W	YES	0
	Bit	11-10	9-8	7-6						
	Channel	DA5	DA4	AD3						
	Bit	5-4	3-2	1-0						
Channel	AD2	AD1	AD0							
	Input setting mode: 00: Voltage mode (-10V ~ 10V) 01: Current mode (-20mA ~ 20mA) 10: Current mode (4 ~ 20mA) Output setting mode:									

Special D	Content	OFF ↓ ON	STOP ↓ RUN	RUN ↓ STOP	Attrib.	Latched	Default
	00: Voltage mode (-10V ~ 10V) 01: Current mode (0mA ~ 20mA) 10: Current mode (4 ~ 20mA)						
D1116	Setting value of analog output channel 0 (DA 0)	0	0	0	R/W	NO	0
D1117	Setting value of analog output channel 1 (DA 1)	0	0	0	R/W	NO	0
D1118	TP04P-20EXL1T Sampling time of analog/digital conversion; unit: 1 ms. If D1118 is ≤ 2 , sampling time default is 2 ms.	2	-	-	R/W	YES	2
D1120	Setting for COM2 (RS-485) communication protocol	H'86	-	-	R/W	NO	H'86
D1121	COM2(RS-485) PLC communication address	-	-	-	R/W	YES	1
D1122	COM2(RS-485) Residual number of words of transmitting data	0	0	-	R	NO	0
D1123	COM2(RS-485) Residual number of words of the receiving data	0	0	-	R	NO	0
D1124	COM2(RS-485) Definition of start character (STX)	H'3A	-	-	R/W	NO	H'3A
D1125	COM2(RS-485) Definition of first ending character (ETX1)	H'0D	-	-	R/W	NO	H'0D
D1126	COM2(RS-485) Definition of second ending character (ETX2)	H'0A	-	-	R/W	NO	H'0A
D1129	COM2 (RS-485) Communication time-out setting (ms)	0	-	-	R/W	NO	0
D1130	COM2 (RS-485) Error code returning from Modbus	0	-	-	R	NO	0
D1137	Address where incorrect use of operand occurs	0	0	-	R	NO	0
D1140	Number of Analog I/O modules (max. 1)	-	-	-	R	NO	1
D1142	Digital input points (X point) TP70P-211LC1T: 17 TP04P-20EXL1T: 9	#	-	-	R	NO	#
D1143	Digital output points (Y point) TP70P-211LC1T: 24 TP04P-20EXL1T: 16	#	-	-	R	NO	#
D1168	When RS instruction this specified end word, it triggers an interruption request (I150) on COM2 (RS-485).	0	-	-	R/W	NO	0
D1182	Index register E1	0	-	-	R/W	NO	0
D1183	Index register F1	0	-	-	R/W	NO	0
D1184	Index register E2	0	-	-	R/W	NO	0
D1185	Index register F2	0	-	-	R/W	NO	0
D1186	Index register E3	0	-	-	R/W	NO	0
D1187	Index register F3	0	-	-	R/W	NO	0
D1188	Index register E4	0	-	-	R/W	NO	0

Special D	Content	OFF ↓ ON	STOP ↓ RUN	RUN ↓ STOP	Attrib.	Latched	Default
D1189	Index register F4	0	-	-	R/W	NO	0
D1190	Index register E5	0	-	-	R/W	NO	0
D1191	Index register F5	0	-	-	R/W	NO	0
D1192	Index register E6	0	-	-	R/W	NO	0
D1193	Index register F6	0	-	-	R/W	NO	0
D1194	Index register E7	0	-	-	R/W	NO	0
D1195	Index register F7	0	-	-	R/W	NO	0
D1240	When interrupt I100/I101 occurs, D1240 stores the low word of high-speed counter.	0	0	-	R	NO	0
D1241	When interrupt I100/I101 occurs, D1240 stores the high word of high-speed counter.	0	0	-	R	NO	0
D1256 ↓ D1295	For COM2 RS-485 MODRW instruction. D1256~D1295 store the sent data of MODRW instruction. When MODRW instruction sends out data, the data will be stored in D1256~D1295. Users can check the sent data in these registers.	0	-	-	R	NO	0
D1296 ↓ D1311	For COM2 RS-485 MODRW instruction. D1296~D1311 store the converted hex data from D1070 ~ D1085 (ASCII). PLC automatically converts the received ASCII data in D1070 ~ D1085 into hex data.	0	-	-	R	NO	0
D1313	Second of RTC: 00 ~ 59	-	-	-	R/W	YES	#
D1314	Minute of RTC: 00 ~ 59	-	-	-	R/W	YES	#
D1315	Hour of RTC: 00 ~ 23	-	-	-	R/W	YES	#
D1316	Day of RTC: 01 ~ 31	-	-	-	R/W	YES	#
D1317	Month of RTC: 01 ~ 12	-	-	-	R/W	YES	#
D1318	Week of RTC: 1 ~ 7	-	-	-	R/W	YES	#
D1319	Year of RTC: 00 ~ 99 (A.D.)	-	-	-	R/W	YES	#
D1320	DRV BD module code TP04P-20EXL1T: H'22 TP70P-211LC1T: H'16	-	-	-	R	NO	H'22 H'16
D1321	IO BD module code TP04P-20EXL1T: H'9C TP70P-211LC1T: H'9C	-	-	-	R	NO	H'9C
D1354	PLC Link scan cycle (Unit: 1ms) ■ Max: K32000 ■ D1354 = K0 when PLC Link stops or when the first scan is complete	0	0	0	R	NO	0
D1355	Starting reference for Master to read from Slave ID#1	-	-	-	R/W	YES	H'1064
D1356	Starting reference for Master to read from Slave ID#2	-	-	-	R/W	YES	H'1064

Special D	Content	OFF ↓ ON	STOP ↓ RUN	RUN ↓ STOP	Attrib.	Latched	Default
D1357	Starting reference for Master to read from Slave ID#3	-	-	-	R/W	YES	H'1064
D1358	Starting reference for Master to read from Slave ID#4	-	-	-	R/W	YES	H'1064
D1359	Starting reference for Master to read from Slave ID#5	-	-	-	R/W	YES	H'1064
D1360	Starting reference for Master to read from Slave ID#6	-	-	-	R/W	YES	H'1064
D1361	Starting reference for Master to read from Slave ID#7	-	-	-	R/W	YES	H'1064
D1362	Starting reference for Master to read from Slave ID#8	-	-	-	R/W	YES	H'1064
D1363	Starting reference for Master to read from Slave ID#9	-	-	-	R/W	YES	H'1064
D1364	Starting reference for Master to read from Slave ID#10	-	-	-	R/W	YES	H'1064
D1365	Starting reference for Master to read from Slave ID#11	-	-	-	R/W	YES	H'1064
D1366	Starting reference for Master to read from Slave ID#12	-	-	-	R/W	YES	H'1064
D1367	Starting reference for Master to read from Slave ID#13	-	-	-	R/W	YES	H'1064
D1368	Starting reference for Master to read from Slave ID#14	-	-	-	R/W	YES	H'1064
D1369	Starting reference for Master to read from Slave ID#15	-	-	-	R/W	YES	H'1064
D1370	Starting reference for Master to read from Slave ID#16	-	-	-	R/W	YES	H'1064
D1399	Starting ID of Slave designated by PLC LINK	-	-	-	R/W	YES	1
D1415	Starting reference for Master to write in Slave ID#1	-	-	-	R/W	YES	H'10C8
D1416	Starting reference for Master to write in Slave ID#2	-	-	-	R/W	YES	H'10C8
D1417	Starting reference for Master to write in Slave ID#3	-	-	-	R/W	YES	H'10C8
D1418	Starting reference for Master to write in Slave ID#4	-	-	-	R/W	YES	H'10C8
D1419	Starting reference for Master to write in Slave ID#5	-	-	-	R/W	YES	H'10C8
D1420	Starting reference for Master to write in Slave ID#6	-	-	-	R/W	YES	H'10C8
D1421	Starting reference for Master to write in Slave ID#7	-	-	-	R/W	YES	H'10C8
D1422	Starting reference for Master to write in Slave ID#8	-	-	-	R/W	YES	H'10C8
D1423	Starting reference for Master to write in Slave ID#9	-	-	-	R/W	YES	H'10C8
D1424	Starting reference for Master to write in Slave ID#10	-	-	-	R/W	YES	H'10C8
D1425	Starting reference for Master to write in Slave ID#11	-	-	-	R/W	YES	H'10C8
D1426	Starting reference for Master to write in Slave ID#12	-	-	-	R/W	YES	H'10C8
D1427	Starting reference for Master to write in Slave ID#13	-	-	-	R/W	YES	H'10C8
D1428	Starting reference for Master to write in Slave ID#14	-	-	-	R/W	YES	H'10C8
D1429	Starting reference for Master to write in Slave ID#15	-	-	-	R/W	YES	H'10C8
D1430	Starting reference for Master to write in Slave ID#16	-	-	-	R/W	YES	H'10C8

5

Special D	Content	OFF ↓ ON	STOP ↓ RUN	RUN ↓ STOP	Attrib.	Latched	Default
D1431	Setting value for times of PLC LINK polling cycle	0	-	-	R/W	NO	0
D1432	Display of current times of PLC LINK polling cycle	0	-	-	R/W	NO	0
D1433	Number of slave units connected to PLC LINK	0	-	-	R/W	NO	0
D1434	Data length to be read on Slave ID#1	-	-	-	R/W	YES	16
D1435	Data length to be read on Slave ID#2	-	-	-	R/W	YES	16
D1436	Data length to be read on Slave ID#3	-	-	-	R/W	YES	16
D1437	Data length to be read on Slave ID#4	-	-	-	R/W	YES	16
D1438	Data length to be read on Slave ID#5	-	-	-	R/W	YES	16
D1439	Data length to be read on Slave ID#6	-	-	-	R/W	YES	16
D1440	Data length to be read on Slave ID#7	-	-	-	R/W	YES	16
D1441	Data length to be read on Slave ID#8	-	-	-	R/W	YES	16
D1442	Data length to be read on Slave ID#9	-	-	-	R/W	YES	16
D1443	Data length to be read on Slave ID#10	-	-	-	R/W	YES	16
D1444	Data length to be read on Slave ID#11	-	-	-	R/W	YES	16
D1445	Data length to be read on Slave ID#12	-	-	-	R/W	YES	16
D1446	Data length to be read on Slave ID#13	-	-	-	R/W	YES	16
D1447	Data length to be read on Slave ID#14	-	-	-	R/W	YES	16
D1448	Data length to be read on Slave ID#15	-	-	-	R/W	YES	16
D1449	Data length to be read on Slave ID#16	-	-	-	R/W	YES	16
D1450	Data length to be written on Slave ID#1	-	-	-	R/W	YES	16
D1451	Data length to be written on Slave ID#2	-	-	-	R/W	YES	16
D1452	Data length to be written on Slave ID#3	-	-	-	R/W	YES	16
D1453	Data length to be written on Slave ID#4	-	-	-	R/W	YES	16
D1454	Data length to be written on Slave ID#5	-	-	-	R/W	YES	16
D1455	Data length to be written on Slave ID#6	-	-	-	R/W	YES	16
D1456	Data length to be written on Slave ID#7	-	-	-	R/W	YES	16
D1457	Data length to be written on Slave ID#8	-	-	-	R/W	YES	16
D1458	Data length to be written on Slave ID#9	-	-	-	R/W	YES	16
D1459	Data length to be written on Slave ID#10	-	-	-	R/W	YES	16
D1460	Data length to be written on Slave ID#11	-	-	-	R/W	YES	16
D1461	Data length to be written on Slave ID#12	-	-	-	R/W	YES	16

Special D	Content	OFF ↓ ON	STOP ↓ RUN	RUN ↓ STOP	Attrib.	Latched	Default
D1462	Data length to be written on Slave ID#13	-	-	-	R/W	YES	16
D1463	Data length to be written on Slave ID#14	-	-	-	R/W	YES	16
D1464	Data length to be written on Slave ID#15	-	-	-	R/W	YES	16
D1465	Data length to be written on Slave ID#16	-	-	-	R/W	YES	16
D1480	The data which is read from slave ID#1 in PLC LINK at the time when M1353 is OFF.	0	-	-	R	NO	0
↓ D1495	The initial data register where the data read from slave ID#1~ID#16 in PLC LINK is stored at the time when M1353 is ON	-	-	-	R	YES	0
D1496	The data which is written into slave ID#1 in PLC LINK at the time when M1353 is OFF.	0	-	-	R/W	NO	0
↓ D1511	The initial data register where the data written into slave ID#1~ID#16 in PLC LINK is stored at the time when M1353 is ON.	-	-	-	R/W	YES	0
D1512 ↓ D1527	The data which is read from slave ID#2 in PLC LINK	0	-	-	R	NO	0
D1528 ↓ D1543	The data which is written into slave ID#2 in PLC LINK	0	-	-	R/W	NO	0
D1544 ↓ D1559	The data which is read from slave ID#3 in PLC LINK	0	-	-	R	NO	0
D1560 ↓ D1575	The data which is written into slave ID#3 in PLC LINK	0	-	-	R/W	NO	0
D1576 ↓ D1591	The data which is read from slave ID#4 in PLC LINK	0	-	-	R	NO	0
D1592 ↓ D1607	The data which is written into slave ID#4 in PLC LINK	0	-	-	R/W	NO	0
D1608 ↓ D1623	The data which is read from slave ID#5 in PLC LINK	0	-	-	R	NO	0
D1624 ↓ D1639	The data which is written into slave ID#5 in PLC LINK	0	-	-	R/W	NO	0
D1640 ↓ D1655	The data which is read from slave ID#6 in PLC LINK	0	-	-	R	NO	0
D1656 ↓ D1671	The data which is written into slave ID#6 in PLC LINK	0	-	-	R/W	NO	0

5

Special D	Content	OFF ↓ ON	STOP ↓ RUN	RUN ↓ STOP	Attrib.	Latched	Default
D1672 ↓ D1687	The data which is read from slave ID#7 in PLC LINK	0	-	-	R	NO	0
D1688 ↓ D1703	The data which is written into slave ID#7 in PLC LINK	0	-	-	R/W	NO	0
D1704 ↓ D1719	The data which is read from slave ID#8 in PLC LINK	0	-	-	R	NO	0
D1720 ↓ D1735	The data which is written into slave ID#8 in PLC LINK	0	-	-	R/W	NO	0
D1736 ↓ D1751	The data which is read from slave ID#9 in PLC LINK	0	-	-	R	NO	0
D1752 ↓ D1767	The data which is written into slave ID#9 in PLC LINK	0	-	-	R/W	NO	0
D1768 ↓ D1783	The data which is read from slave ID#10 in PLC LINK	0	-	-	R	NO	0
D1784 ↓ D1799	The data which is written into slave ID#10 in PLC LINK	0	-	-	R/W	NO	0
D1800 ↓ D1815	The data which is read from slave ID#11 in PLC LINK	0	-	-	R	NO	0
D1816 ↓ D1831	The data which is written into slave ID#11 in PLC LINK	0	-	-	R/W	NO	0
D1832 ↓ D1847	The data which is read from slave ID#12 in PLC LINK	0	-	-	R	NO	0
D1848 ↓ D1863	The data which is written into slave ID#12 in PLC LINK	0	-	-	R/W	NO	0
D1864 ↓ D1879	The data which is read from slave ID#13 in PLC LINK	0	-	-	R	NO	0
D1880 ↓ D1895	The data which is written into slave ID#13 in PLC LINK	0	-	-	R/W	NO	0
D1896 ↓ D1911	The data which is read from slave ID#14 in PLC LINK	0	-	-	R	NO	0
D1912	The data to be written into slave ID#14 in PLC LINK; the	0	-	-	R/W	NO	0

Special D	Content	OFF ↓ ON	STOP ↓ RUN	RUN ↓ STOP	Attrib.	Latched	Default
↓ D1927	starting reference for Slave to write is defined in D1428; default is to write 16 pieces of data starting from H'10C8.						
D1928 ↓ D1943	The data to be read from slave ID#15 in PLC LINK; the starting reference for Slave to write is defined in D1369; default is to read 16 pieces of data starting from H'1064.	0	-	-	R	NO	0
D1944 ↓ D1959	The data to be written into slave ID#15 in PLC LINK; the starting reference for Slave to write is defined in D1429; default is to write 16 pieces of data starting from H'10C8.	0	-	-	R/W	NO	0
D1960 ↓ D1975	The data to be read from slave ID#16 in PLC LINK; the starting reference for Slave to write is defined in D1370; default is to read 16 pieces of data starting from H'1064.	0	-	-	R	NO	0
D1976 ↓ D1991	The data to be written into slave ID#16 in PLC LINK; the starting reference for Slave to write is defined in D1430; default is to write 16 pieces of data starting from H'10C8.	0	-	-	R/W	NO	0

5.3 Special Auxiliary Relay

The types and functions of special auxiliary relays (special M) are listed in the table below. Some registers of the same No. may bear different meanings for different PLC series. "R" in the column of Attribute refers to "read only" and "R/W" refers to "read and write"; "-" refers to the status remains unchanged and "#" refers to the setting is based on the PLC setting status.

Special M	Content	OFF ↓ ON	STOP ↓ RUN	RUN ↓ STOP	Attrib.	Latched	Default
M1000	Monitor contact A (normally open)	OFF	ON	OFF	R	NO	OFF
M1001	Monitor contact B (normally close)	ON	OFF	ON	R	NO	ON
M1002	Enable single positive pulse at the moment when RUN is activate (Normally OFF)	OFF	ON	OFF	R	NO	OFF
M1003	Enable single negative pulse at the moment when RUN is activate (Normally ON)	ON	OFF	ON	R	NO	ON
M1004	ON when syntax errors occur	OFF	OFF	-	R	NO	OFF
M1008	Watchdog timer (ON: PLC WDT time out)	OFF	OFF	-	R	NO	OFF
M1009	LV signal indicates insufficient power supply 24 VDC	OFF	-	-	R	NO	OFF
M1011	10 ms clock pulse, 5ms ON/5ms OFF	OFF	-	-	R	NO	OFF
M1012	100 ms clock pulse, 50ms ON / 50ms OFF	OFF	-	-	R	NO	OFF
M1013	1 s clock pulse, 0.5s ON / 0.5s OFF	OFF	-	-	R	NO	OFF
M1014	1 min clock pulse, 30s ON / 30s OFF	OFF	-	-	R	NO	OFF
M1016	RTC display; OFF: display the last 2 digits of the year; ON: display 4 digits of the year	OFF	-	-	R/W	NO	OFF
M1017	±30 seconds correction on real time clock	OFF	-	-	R/W	NO	OFF

Special M	Content	OFF ↓ ON	STOP ↓ RUN	RUN ↓ STOP	Attrib.	Latched	Default
M1020	Zero flag	OFF	-	-	R	NO	OFF
M1021	Borrow flag	OFF	-	-	R	NO	OFF
M1022	Carry Flag	OFF	-	-	R	NO	OFF
M1024	COM1 monitor request	OFF	-	-	R/W	NO	OFF
M1025	Incorrect communication request	OFF	-	-	R	NO	OFF
M1026	RAMP mode selection	OFF	-	-	R/W	NO	OFF
M1027	PR output mode selection	OFF	-	-	R/W	NO	OFF
M1028	Switch T64~T126 timer resolution between 10 ms and 100 ms. ON =10 ms	OFF	-	-	R/W	NO	OFF
M1031	Clear all non-latched memory	OFF	-	-	R/W	NO	OFF
M1032	Clear all latched memory	OFF	-	-	R/W	NO	OFF
M1033	When M1033 = ON, PLC outputs will be latched when PLC is switched from RUN to STOP.	OFF	-	-	R/W	NO	OFF
M1034	Disable all Y outputs	OFF	-	-	R/W	NO	OFF
M1035	Enable X7 input point as RUN/STOP switch	-	-	-	R/W	YES	OFF
M1038	Switch T200~T255 timer resolution between 10 ms and 1 ms. ON =1 ms	OFF	-	-	R/W	NO	OFF
M1039	Fixed scan time mode	OFF	-	-	R/W	NO	OFF
M1040	Disable step transition	OFF	-	-	R/W	NO	OFF
M1041	Enable step transition	OFF	-	OFF	R/W	NO	OFF
M1042	Enable pulse operation	OFF	-	-	R/W	NO	OFF
M1043	Zero return complete	OFF	-	OFF	R/W	NO	OFF
M1044	Condition of zero return	OFF	-	OFF	R/W	NO	OFF
M1045	Disable "all output reset" function	OFF	-	-	R/W	NO	OFF
M1046	STL (Step Ladder) status is ON	OFF	-	-	R	NO	OFF
M1047	Enable STL monitoring	OFF	-	-	R/W	NO	OFF
M1048	Alarm status is ON	OFF	-	-	R	NO	OFF
M1049	Enable alarm monitoring	OFF	-	-	R/W	NO	OFF
M1050	Disable interrupt I000 / I001	OFF	-	-	R/W	NO	OFF
M1051	Disable interrupt I100 / I101	OFF	-	-	R/W	NO	OFF
M1059	Disable interrupt I010	OFF	-	-	R/W	NO	OFF
M1060	System error message 1	OFF	-	-	R	NO	OFF
M1061	System error message 2	OFF	-	-	R	NO	OFF
M1062	System error message 3	OFF	-	-	R	NO	OFF

Special M	Content	OFF ↓ ON	STOP ↓ RUN	RUN ↓ STOP	Attrib.	Latched	Default
M1063	System error message 4	OFF	-	-	R	NO	OFF
M1064	Incorrect use of operands	OFF	OFF	-	R	NO	OFF
M1065	Syntax error	OFF	OFF	-	R	NO	OFF
M1066	Loop error	OFF	OFF	-	R	NO	OFF
M1067	Program execution error	OFF	OFF	-	R	NO	OFF
M1068	Execution error locked (D1068)	OFF	-	-	R	NO	OFF
M1072	PLC status (RUN/STOP), ON = RUN	OFF	ON	OFF	R/W	NO	OFF
M1075	Error occurring when write in Flash ROM	OFF	-	-	R	NO	OFF
M1080	COM2 monitor request	OFF	-	-	R/W	NO	OFF
M1081	Changing conversion mode for FLT instruction	OFF	-	-	R/W	NO	OFF
M1088	Matrix comparison; comparing between equivalent values (M1088 = ON) or different values (M1088 = OFF).	OFF	OFF	-	R/W	NO	OFF
M1089	The end of matrix comparison; when the comparison reaches the last bit, M1089 = ON.	OFF	OFF	-	R	NO	OFF
M1090	The start of matrix comparison; when the comparison starts from the first bit, M1090 = ON.	OFF	OFF	-	R	NO	OFF
M1091	Matrix searching results; when finding matched results, comparison will stop immediately and M1091 = ON.	OFF	OFF	-	R	NO	OFF
M1092	Pointer error; when the pointer Pr exceeds the comparison range, M1092 = ON	OFF	OFF	-	R	NO	OFF
M1093	Matrix pointer accumulated flag. Adding 1 to the current value of the Pr.	OFF	OFF	-	R/W	NO	OFF
M1094	Matrix pointer clear flag. Clear the current value of the Pr to 0	OFF	OFF	-	R/W	NO	OFF
M1095	Carry flag for matrix rotation/shift/output.	OFF	OFF	-	R	NO	OFF
M1096	Borrow flag for matrix rotation/shift/input	OFF	OFF	-	R/W	NO	OFF
M1097	Direction flag for matrix rotation/displacement	OFF	OFF	-	R/W	NO	OFF
M1098	Counting the number of bits which are "1" or "0"	OFF	OFF	-	R/W	NO	OFF
M1099	ON when the bits counting result is "0"	OFF	OFF	-	R/W	NO	OFF
M1120	Retaining the communication setting of COM2 (RS-485), D1120 cannot be modified, when M1120 is set.	OFF	OFF	-	R/W	NO	OFF
M1121	Data waiting to be sent via COM2 (RS-485)	OFF	ON	-	R	NO	OFF
M1122	Request of sending via COM2 (RS-485)	OFF	OFF	-	R/W	NO	OFF
M1123	Data received completely via COM2 (RS-485)	OFF	OFF	-	R/W	NO	OFF
M1124	Waiting to receive data via COM2 (RS-485)	OFF	OFF	-	R/W	NO	OFF
M1125	Reset communication status of COM2 (RS-485)	OFF	OFF	OFF	R/W	NO	OFF
M1126	set STX/ETX as user defined or system defined for COM2 (RS-485)	OFF	OFF	OFF	R/W	NO	OFF

Special M	Content	OFF ↓ ON	STOP ↓ RUN	RUN ↓ STOP	Attrib.	Latched	Default
M1127	Data sending / receiving / converting completed via COM2 (RS-485); RS instruction is not supported	OFF	OFF	OFF	R/W	NO	OFF
M1128	Data sending / receiving indicator for COM2 (RS-485)	OFF	OFF	OFF	R/W	NO	OFF
M1129	Receiving time out via COM2 (RS-485)	OFF	OFF	-	R/W	NO	OFF
M1130	STX/ETX selection via COM2 (RS-485)	OFF	OFF	-	R/W	NO	OFF
M1131	M1131=ON when MODRD/RDST/MODRW data is being converted from ASCII to Hex via COM2 (RS-485)	OFF	OFF	-	R	NO	OFF
M1132	ON when there are no communication related instructions in the program	OFF	-	-	R	NO	OFF
M1140	Data receiving error of MODRD/MODWR/MODRW via COM2 (RS-485)	OFF	OFF	-	R	NO	OFF
M1141	Parameter error of MODRD/MODWR/MODRW via COM2 (RS-485)	OFF	OFF	-	R	NO	OFF
M1142	Data receiving error of VFD-A handy instruction via COM2 (RS-485)	OFF	OFF	-	R	NO	OFF
M1143	ASCII/RTU selection (OFF: ASCII; ON: RTU) for COM2 (RS-485)	OFF	-	-	R/W	NO	OFF
M1161	8/16 bit mode (ON = 8 bit mode)	OFF	-	-	R/W	NO	OFF
M1162	Switching between decimal integer and binary floating point for SCLP instruction. ON: binary floating point; OFF: decimal integer	OFF	-	-	R/W	NO	OFF
M1167	16-bit mode for HKY input	OFF	-	-	R/W	NO	OFF
M1168	Designating work mode of SMOV	OFF	-	-	R/W	NO	OFF
M1177	Enable the communication instruction for Delta VFD series inverter. ON: VFD-A (Default), OFF: other models of VFD	OFF	-	-	R/W	NO	OFF
M1200	C200 counting mode (ON: count down)	OFF	-	-	R/W	NO	OFF
M1201	C201 counting mode (ON: count down)	OFF	-	-	R/W	NO	OFF
M1202	C202 counting mode (ON: count down)	OFF	-	-	R/W	NO	OFF
M1203	C203 counting mode (ON: count down)	OFF	-	-	R/W	NO	OFF
M1204	C204 counting mode (ON: count down)	OFF	-	-	R/W	NO	OFF
M1205	C205 counting mode (ON :count down)	OFF	-	-	R/W	NO	OFF
M1206	C206 counting mode (ON: count down)	OFF	-	-	R/W	NO	OFF
M1207	C207 counting mode (ON: count down)	OFF	-	-	R/W	NO	OFF
M1208	C208 counting mode (ON: count down)	OFF	-	-	R/W	NO	OFF
M1209	C209 counting mode (ON: count down)	OFF	-	-	R/W	NO	OFF
M1210	C210 counting mode (ON: count down)	OFF	-	-	R/W	NO	OFF
M1211	C211 counting mode (ON: count down)	OFF	-	-	R/W	NO	OFF
M1212	C212 counting mode (ON: count down)	OFF	-	-	R/W	NO	OFF
M1213	C213 counting mode (ON: count down)	OFF	-	-	R/W	NO	OFF

Special M	Content	OFF ↓ ON	STOP ↓ RUN	RUN ↓ STOP	Attrib.	Latched	Default
M1214	C214 counting mode (ON: count down)	OFF	-	-	R/W	NO	OFF
M1215	C215 counting mode (ON: count down)	OFF	-	-	R/W	NO	OFF
M1216	C216 counting mode (ON: count down)	OFF	-	-	R/W	NO	OFF
M1217	C217 counting mode (ON: count down)	OFF	-	-	R/W	NO	OFF
M1218	C218 counting mode (ON: count down)	OFF	-	-	R/W	NO	OFF
M1219	C219 counting mode (ON: count down)	OFF	-	-	R/W	NO	OFF
M1220	C220 counting mode (ON: count down)	OFF	-	-	R/W	NO	OFF
M1221	C221 counting mode (ON: count down)	OFF	-	-	R/W	NO	OFF
M1222	C222 counting mode (ON: count down)	OFF	-	-	R/W	NO	OFF
M1223	C223 counting mode (ON: count down)	OFF	-	-	R/W	NO	OFF
M1224	C224 counting mode (ON: count down)	OFF	-	-	R/W	NO	OFF
M1225	C225 counting mode (ON: count down)	OFF	-	-	R/W	NO	OFF
M1226	C226 counting mode (ON: count down)	OFF	-	-	R/W	NO	OFF
M1227	C227 counting mode (ON: count down)	OFF	-	-	R/W	NO	OFF
M1228	C228 counting mode (ON: count down)	OFF	-	-	R/W	NO	OFF
M1229	C229 counting mode (ON: count down)	OFF	-	-	R/W	NO	OFF
M1230	C230 counting mode (ON: count down)	OFF	-	-	R/W	NO	OFF
M1231	C231 counting mode (ON: count down)	OFF	-	-	R/W	NO	OFF
M1232	C232 counting mode (ON: count down)	OFF	-	-	R/W	NO	OFF
M1233	C232 counter monitor (ON: count down)	OFF	-	-	R	NO	OFF
M1234	C233 counter monitor (ON: count down)	OFF	-	-	R	NO	OFF
M1235	C234 counter monitor (ON: count down)	OFF	-	-	R/W	NO	OFF
M1236	C235 counting mode (ON: count down)	OFF	-	-	R/W	NO	OFF
M1237	C236 counting mode (ON: count down)	OFF	-	-	R/W	NO	OFF
M1238	C237 counting mode (ON: count down)	OFF	-	-	R/W	NO	OFF
M1239	C238 counting mode (ON: count down)	OFF	-	-	R/W	NO	OFF
M1240	C239 counting mode (ON: count down)	OFF	-	-	R/W	NO	OFF
M1241	C240 counting mode (ON: count down)	OFF	-	-	R/W	NO	OFF
M1242	C241 counting mode (ON: count down)	OFF	-	-	R/W	NO	OFF
M1243	C243 Reset function control. ON = R function disabled	OFF	-	-	R/W	NO	OFF
M1244	C244 Reset function control. ON = R function disabled	OFF	-	-	R/W	NO	OFF

Special M	Content	OFF ↓ ON	STOP ↓ RUN	RUN ↓ STOP	Attrib.	Latched	Default
M1245	C245 counter monitor (ON: count down)	OFF	-	-	R	NO	OFF
M1246	C246 counter monitor (ON: count down)	OFF	-	-	R	NO	OFF
M1247	C247 counter monitor (ON: count down)	OFF	-	-	R	NO	OFF
M1248	C248 counter monitor (ON: count down)	OFF	-	-	R	NO	OFF
M1249	C249 counter monitor (ON: count down)	OFF	-	-	R	NO	OFF
M1250	C250 counter monitor (ON: count down)	OFF	-	-	R	NO	OFF
M1251	C251 counter monitor (ON: count down)	OFF	-	-	R	NO	OFF
M1252	C252 counter monitor (ON: count down)	OFF	-	-	R	NO	OFF
M1253	C253 counter monitor (ON: count down)	OFF	-	-	R	NO	OFF
M1254	C254 counter monitor (ON: count down)	OFF	-	-	R	NO	OFF
M1270	C235 counting mode (ON: falling-edge count)	OFF	-	-	R/W	NO	OFF
M1271	C236 counting mode (ON: falling-edge count)	OFF	-	-	R/W	NO	OFF
M1272	C237 counting mode (ON: falling-edge count)	OFF	-	-	R/W	NO	OFF
M1273	C238 counting mode (ON: falling-edge count)	OFF	-	-	R/W	NO	OFF
M1274	C239 counting mode (ON: falling-edge count)	OFF	-	-	R/W	NO	OFF
M1275	C240 counting mode (ON: falling-edge count)	OFF	-	-	R/W	NO	OFF
M1276	C241 counting mode (ON: falling-edge count)	OFF	-	-	R/W	NO	OFF
M1277	C242 counting mode (ON: falling-edge count)	OFF	-	-	R/W	NO	OFF
M1280	For I000 / I001, reverse interrupt trigger pulse direction (Rising/Falling)	OFF	OFF	-	R/W	NO	OFF
M1284	For I400 / I401, reverse interrupt trigger pulse direction (Rising/Falling)	OFF	OFF	-	R/W	NO	OFF
M1303	High / low bits exchange for XCH instruction	OFF	-	-	R/W	NO	OFF
M1304	Enable force-ON/OFF of input point X	OFF	-	-	R/W	NO	OFF
M1350	Enable PLC LINK	OFF	-	OFF	R/W	NO	OFF
M1351	Enable auto mode on PLC LINK	OFF	-	-	R/W	NO	OFF
M1352	Enable manual mode on PLC LINK	OFF	-	-	R/W	NO	OFF
M1353	Enable access up to 50 words through PLC LINK (If M1353 is ON, D1480~D1511 are latched devices.)	-	-	-	R/W	YES	OFF
M1354	Enable simultaneous data read/write in a polling of PLC LINK	-	-	-	R/W	YES	OFF
M1355	Select Slave linking mode in PLC LINK (ON: manual; OFF: auto-detection)	-	-	-	R/W	YES	OFF
M1360	Slave ID#1 status in PLC LINK	-	-	-	R/W	YES	OFF
M1361	Slave ID#2 status in PLC LINK	-	-	-	R/W	YES	OFF

Special M	Content	OFF ↓ ON	STOP ↓ RUN	RUN ↓ STOP	Attrib.	Latched	Default
M1362	Slave ID#3 status in PLC LINK	-	-	-	R/W	YES	OFF
M1363	Slave ID#4 status in PLC LINK	-	-	-	R/W	YES	OFF
M1364	Slave ID#5 status in PLC LINK	-	-	-	R/W	YES	OFF
M1365	Slave ID#6 status in PLC LINK	-	-	-	R/W	YES	OFF
M1366	Slave ID#7 status in PLC LINK	-	-	-	R/W	YES	OFF
M1367	Slave ID#8 status in PLC LINK	-	-	-	R/W	YES	OFF
M1368	Slave ID#9 status in PLC LINK	-	-	-	R/W	YES	OFF
M1369	Slave ID#10 status in PLC LINK	-	-	-	R/W	YES	OFF
M1370	Slave ID#11 status in PLC LINK	-	-	-	R/W	YES	OFF
M1371	Slave ID#12 status in PLC LINK	-	-	-	R/W	YES	OFF
M1372	Slave ID#13 status in PLC LINK	-	-	-	R/W	YES	OFF
M1373	Slave ID#14 status in PLC LINK	-	-	-	R/W	YES	OFF
M1374	Slave ID#15 status in PLC LINK	-	-	-	R/W	YES	OFF
M1375	Slave ID#16 status in PLC LINK	-	-	-	R/W	YES	OFF
M1376	Slave ID#1 data exchange status in PLC LINK	OFF	-	-	R	NO	OFF
M1377	Slave ID#2 data exchange status in PLC LINK	OFF	-	-	R	NO	OFF
M1378	Slave ID#3 data exchange status in PLC LINK	OFF	-	-	R	NO	OFF
M1379	Slave ID#4 data exchange status in PLC LINK	OFF	-	-	R	NO	OFF
M1380	Slave ID#5 data exchange status in PLC LINK	OFF	-	-	R	NO	OFF
M1381	Slave ID#6 data exchange status in PLC LINK	OFF	-	-	R	NO	OFF
M1382	Slave ID#7 data exchange status in PLC LINK	OFF	-	-	R	NO	OFF
M1383	Slave ID#8 data exchange status in PLC LINK	OFF	-	-	R	NO	OFF
M1384	Slave ID#9 data exchange status in PLC LINK	OFF	-	-	R	NO	OFF
M1385	Slave ID#10 data exchange status in PLC LINK	OFF	-	-	R	NO	OFF
M1386	Slave ID#11 data exchange status in PLC LINK	OFF	-	-	R	NO	OFF
M1387	Slave ID#12 data exchange status in PLC LINK	OFF	-	-	R	NO	OFF
M1388	Slave ID#13 data exchange status in PLC LINK	OFF	-	-	R	NO	OFF
M1389	Slave ID#14 data exchange status in PLC LINK	OFF	-	-	R	NO	OFF
M1390	Slave ID#15 data exchange status in PLC LINK	OFF	-	-	R	NO	OFF
M1391	Slave ID#16 data exchange status in PLC LINK	OFF	-	-	R	NO	OFF
M1392	Slave ID#1 connection error	OFF	-	-	R	NO	OFF

Special M	Content	OFF ↓ ON	STOP ↓ RUN	RUN ↓ STOP	Attrib.	Latched	Default
M1393	Slave ID#2 connection error	OFF	-	-	R	NO	OFF
M1394	Slave ID#3 connection error	OFF	-	-	R	NO	OFF
M1395	Slave ID#4 connection error	OFF	-	-	R	NO	OFF
M1396	Slave ID#5 connection error	OFF	-	-	R	NO	OFF
M1397	Slave ID#6 connection error	OFF	-	-	R	NO	OFF
M1398	Slave ID#7 connection error	OFF	-	-	R	NO	OFF
M1399	Slave ID#8 connection error	OFF	-	-	R	NO	OFF
M1400	Slave ID#9 connection error	OFF	-	-	R	NO	OFF
M1401	Slave ID#10 connection error	OFF	-	-	R	NO	OFF
M1402	Slave ID#11 connection error	OFF	-	-	R	NO	OFF
M1403	Slave ID#12 connection error	OFF	-	-	R	NO	OFF
M1404	Slave ID#13 connection error	OFF	-	-	R	NO	OFF
M1405	Slave ID#14 connection error	OFF	-	-	R	NO	OFF
M1406	Slave ID#15 connection error	OFF	-	-	R	NO	OFF
M1407	Slave ID#16 connection error	OFF	-	-	R	NO	OFF
M1408	Reading from ID#1 is complete	OFF	-	-	R	NO	OFF
M1409	Reading from ID#2 is complete	OFF	-	-	R	NO	OFF
M1410	Reading from ID#3 is complete	OFF	-	-	R	NO	OFF
M1411	Reading from ID#4 is complete	OFF	-	-	R	NO	OFF
M1412	Reading from ID#5 is complete	OFF	-	-	R	NO	OFF
M1413	Reading from ID#6 is complete	OFF	-	-	R	NO	OFF
M1414	Reading from ID#7 is complete	OFF	-	-	R	NO	OFF
M1415	Reading from ID#8 is complete	OFF	-	-	R	NO	OFF
M1416	Reading from ID#9 is complete	OFF	-	-	R	NO	OFF
M1417	Reading from ID#10 is complete	OFF	-	-	R	NO	OFF
M1418	Reading from ID#11 is complete	OFF	-	-	R	NO	OFF
M1419	Reading from ID#12 is complete	OFF	-	-	R	NO	OFF
M1420	Reading from ID#13 is complete	OFF	-	-	R	NO	OFF
M1421	Reading from ID#14 is complete	OFF	-	-	R	NO	OFF
M1422	Reading from ID#15 is complete	OFF	-	-	R	NO	OFF
M1423	Reading from ID#16 is complete	OFF	-	-	R	NO	OFF

Special M	Content	OFF ↓ ON	STOP ↓ RUN	RUN ↓ STOP	Attrib.	Latched	Default
M1424	Writing to ID#1 is complete	OFF	-	-	R	NO	OFF
M1425	Writing to ID#2 is complete	OFF	-	-	R	NO	OFF
M1426	Writing to ID#3 is complete	OFF	-	-	R	NO	OFF
M1427	Writing to ID#4 is complete	OFF	-	-	R	NO	OFF
M1428	Writing to ID#5 is complete	OFF	-	-	R	NO	OFF
M1429	Writing to ID#6 is complete	OFF	-	-	R	NO	OFF
M1430	Writing to ID#7 is complete	OFF	-	-	R	NO	OFF
M1431	Writing to ID#8 is complete	OFF	-	-	R	NO	OFF
M1432	Writing to ID#9 is complete	OFF	-	-	R	NO	OFF
M1433	Writing to ID#10 is complete	OFF	-	-	R	NO	OFF
M1434	Writing to ID#11 is complete	OFF	-	-	R	NO	OFF
M1435	Writing to ID#12 is complete	OFF	-	-	R	NO	OFF
M1436	Writing to ID#13 is complete	OFF	-	-	R	NO	OFF
M1437	Writing to ID#14 is complete	OFF	-	-	R	NO	OFF
M1438	Writing to ID#15 is complete	OFF	-	-	R	NO	OFF
M1439	Writing to ID#16 is complete	OFF	-	-	R	NO	OFF
M1580	Succeed to use DABSR instruction to read Delta ASD-A2	OFF	-	-	R/W	NO	OFF
M1581	Failed to use DABSR instruction to read Delta ASD-A2	OFF	-	-	R/W	NO	OFF
M1662	TP setting page	OFF	-	-	W	NO	OFF
M1666	Read data from special data registers (D4530-D4699) Once the data is read, the status switches to OFF.	OFF	-	-	W	NO	OFF
M1667	Write data into special data registers (D4530-D4699) Once the data is written, the status switches to OFF.	OFF	-	-	W	NO	OFF

5

5.4 Special Data Registers Specific for TP Series

The types and functions of special data registers (special D) for TP04P-20EXL and TP70P-211LC1T are listed in the table below. “X” in the column of Attribute refers to unretentive and “O” refers to retentive (latched). “Ⓞ”

indicates you need to write “H’5678” in D4600 to have the data written into Flash and then the data is retentive.

D4530-D4699 should work with M1666 and M1667 to read or write. When M1666 is ON, the data is read for once. When M1667 is ON, the data is written for once.

Special D	Item	Description	Attributes		Default
D4300	IO1 channel output value	K0 ~ K32000	R/W	X	K0
D4301	IO2 channel output value	K0 ~ K32000	R/W	X	K0
D4302	IO3 channel output value	K0 ~ K32000	R/W	X	K0
D4303	IO4 channel output value	K0 ~ K32000	R/W	X	K0
D4304	Digital Output	H’0000 ~ H’00FF ; Y20 ~ Y27	R/W	X	H’0
D4305	Digital Input	K0 ~ K1 ; X20	R	X	--
D4306	Raw data (Low word)		R	X	--
D4307	Raw data (High word)		R	X	--
D4308	Weight value (Low word)	Current weight value	R	X	--
D4309	Weight value (High word)		R	X	--
D4310	Status code	b0 (H’0001): exceeding weight upper limit b1 (H’0002): empty b2 (H’0004): measured value is stable b3 (H’0008): display value (DV) is stable	R	X	--
D4311	Error status code	b0 (H’0001): Error exists in the power supply b1 (H’0002): Error exists in the module hardware b2 (H’0004): weight exceeds the maximum weight that can be measured or the voltage of SEN is incorrect b3 (H’0008): calibration error	R	X	--
D4312	Weight display value (DV) (Low word)	Present weight value	R	X	--
D4313	Weight display value (DV) (High word)	Present weight value	R	X	--
D4320	AX CH1 PV	Present weight value of CH1; when the value is K-32765 (H8002), it indicates an error occurs and temperature cannot be obtained	R	X	--
D4323	AX CH1 sensor type	K-1: channel closed K0: 0 ~ 5 V (default) K1: 0 ~ 10 V K2: 0 ~ 20 mA	R/W	O	K0
D4323	AX CH1 sensor type	K3: 4 ~ 20 mA K4: 0 ~ 50 mV K5: Pt100 K6: JPt100 K7: Pt1000 K21: Cu50 K22: Cu100	R/W	O	K0

Special D	Item	Description	Attributes		Default
		K23: Ni100 K24: Ni1000 K25: LG-Ni1000			
D4324	AX CH1 measurement unit	K0: °C; K1: °F	R/W	O	K0
D4325	AX CH1 offset	K-999 ~ K999	R/W	O	K0
D4330	AX CH2 PV	Present weight value of CH2; when the value is K-32765 (H8002), it indicates an error occurs and temperature cannot be obtained	R	X	--
D4333	AX CH2 sensor type	K-1: channel closed K0: 0 ~ 5V (default) K1: 0 ~ 10V K2: 0 ~ 20 mA K3: 4 ~ 20 mA K4: 0 ~ 50 mV K5: Pt100 K6: JPt100 K7: Pt1000 K21: Cu50 K22: Cu100 K23: Ni100 K24: Ni1000 K25: LG-Ni1000	R/W	O	K0
D4334	AX CH2 measurement unit	K0: °C; K1: °F	R/W	O	K0
D4335	AX CH2 offset	K-999 ~ K999	R/W	O	K0
D4340	AX error code	b1: Error exists in the module hardware b2: Conversion error in channel 1 b3: Conversion error in channel 2	R	X	--
D4350	IO1 analog output mode	K0: 4 ~ 20 mA (default) K1: 0 ~ 20 mA	R/W	O	K0
D4351	IO2 analog output mode	K0: 4 ~ 20 mA (default) K1: 0 ~ 20 mA	R/W	O	K0
D4352	IO3 analog output mode	K0: 4 ~ 20 mA (default) K1: 0 ~ 20 mA	R/W	O	K0
D4353	IO4 analog output mode	K0: 4 ~ 20 mA (default) K1: 0 ~ 20 mA	R/W	O	K0
D4530	Eigenvalue	Refer to section 3.1.1 for details	R/W	⊙	K1
D4531	Weight measured time	K0: 2.5 ms K1: 10 ms K2: 16 ms K3: 20 ms K4: 50 ms (default) K5: 60 ms K6: 100 ms K7: 200 ms K8: 400 ms	R/W	⊙	K4
D4532	Subtract tare	K0: disable K1: subtract tare	R/W	⊙	K0

5

Special D	Item	Description	Attributes		Default
		K2: not subtract tare K3: reset to zero Once the setting is done, the status switches back to ON. (M1667 = ON)			
D4533	Gross / net weight selection	K0: gross weight ; K1: net weight	R/W	⊙	K0
D4534	Times to check the stability	K1 ~ K500	R/W	⊙	K5
D4535	Times to check the stability range	K1 ~ K10000	R/W	⊙	K10
D4536	Upper limit of the zero return	K0 ~ K32767	R/W	⊙	K10
D4537	Lower limit of the zero return	K-1 ~ K-32768	R/W	⊙	K-10
D4538	Excitation voltage setting	Unit 0.1 V; setting range: K20 ~ K100	R/W	⊙	K50
D4539	Maximum weight (Low word)	You can set the maximum value and when the measured weight exceeding the maximum value, an error code will be recorded.	R/W	⊙	K100000
D4540	Maximum weight (High word)		R/W	⊙	
D4541	Filter mode setting	K0: no filter K1: filter out the measured maximum weight K2: average weights	R/W	⊙	K0
D4542	Mode of filtering out the measured maximum weight	K0 ~ K8 The greater the setting value is, the greater the filtering is	R/W	⊙	K0
D4543	Mode of averaging weights	K1 ~ K100	R/W	⊙	K1
D4544	Setting how many digits can be set on the left of the decimal point	K0 ~ K4	R/W	⊙	K0
D4549	Zero point tracking range	Setting range: K0 ~ K30000; when set the setting to 0, it indicates zero point tracking is disabled.	R/W	⊙	K0
D4550	Zero point tracking time	Setting range: K5 ~ K1000; unit: 0.1 s	R/W	⊙	K5
D4551	Weight value before resetting to zero (Low word)	Display the weight value before resetting to zero	R	⊙	K0
D4552	Weight value before resetting to zero (High word)		R	⊙	K0
D4553	Display tare weight (Low word)	Display tare weight	R/W	X	K0
D4554	Display tare weight (High word)	Work with D4532=1 to edit the tare weight When D4532=2, the tare weight cannot be edit.	R/W	X	K0
D4555	Display the time of the weight measured	Setting range: K0 ~ K10000; unit: 1 ms; K0: present weight	R/W	⊙	K1000

Special D	Item	Description	Attributes	Default									
D4562	Digital input modes X20	Mode setting: H'0: digital input point (default) H'1: ON; a weight is restore to zero H'2: ON; a tare is measured H'3: ON; a tare is subtracted H'4: OFF; a net weight is measured; ON; a gross weight is measured H'6: ON; zero point is calibrated H'7: ON; the 1 st point is calibrated H'8: rising edge triggered; open outputs Y20 ~ Y27 falling edge triggered: close outputs Y20 ~ Y27 H'9: rising edge triggered; close outputs Y20 ~ Y27 falling edge triggered: open outputs Y20 ~ Y27 H'A: rising edge triggered; hold outputs Y20 ~ Y27 falling edge triggered: open outputs Y20 ~ Y27 H'B: rising edge triggered; open outputs Y20 ~ Y27 falling edge triggered: hold outputs Y20 ~ Y27	R/W	⊙	H'0								
		H'A and H'B: <ul style="list-style-type: none"> When the status is Hold, the status of Y20-Y27 cannot be changed; D566 = 2 (HOLD) When the status is Open, output the status of the modified Y20-Y27. 	R/W	⊙	H'0								
D4563	Digital output modes Y20 ~ Y23	<table border="1" style="margin-left: auto; margin-right: auto;"> <tr> <td>b15-b12</td> <td>b11-b8</td> <td>b7-b4</td> <td>b3-b0</td> </tr> <tr> <td>Y23</td> <td>Y22</td> <td>Y21</td> <td>Y20</td> </tr> </table> H'0: digital output point (default) H'1: ON, when there is no load on the load cell H'2: OFF, when there is no load on the load cell H'3: ON, when the weight is larger than the specified maximum weight H'4: OFF, when the weight is larger than the specified maximum weight H'5: ON, when the excitation voltage is abnormal H'6: OFF when the excitation voltage is abnormal F H'7: ON, when the weight is in the specified stability range H'8: OFF, when the weight is in the specified stability range H'9: ON, when the weight is greater than the	b15-b12	b11-b8	b7-b4	b3-b0	Y23	Y22	Y21	Y20	R/W	⊙	H'0
b15-b12	b11-b8	b7-b4	b3-b0										
Y23	Y22	Y21	Y20										

5

Special D	Item	Description	Attributes	Default									
		weight value that is set to output H'A: OFF, when the weight is greater than the Weight value that is set to output											
D4564	Digital output modes Y24 ~ Y27	<table border="1"> <thead> <tr> <th>b15-b12</th> <th>b11-b8</th> <th>b7-b4</th> <th>b3-b0</th> </tr> </thead> <tbody> <tr> <td>Y27</td> <td>Y26</td> <td>Y25</td> <td>Y24</td> </tr> </tbody> </table> <p>H'0: digital output point (default) H'1: ON, when there is no load on the load cell H'2: OFF, when there is no load on the load cell H'3: ON, when the weight is larger than the specified maximum weight H'4: OFF, when the weight is larger than the specified maximum weight H'5: ON, when the excitation voltage is abnormal H'6: OFFm when the excitation voltage is abnormal F H'7: ON, when the weight is in the specified stability range H'8: OFF, when the weight is in the specified stability range H'9: ON, when the weight is greater than the weight value that is set to output H'A: OFF, when the weight is greater than the weight value that is set to output</p>	b15-b12	b11-b8	b7-b4	b3-b0	Y27	Y26	Y25	Y24	R/W	⊙	H'0
b15-b12	b11-b8	b7-b4	b3-b0										
Y27	Y26	Y25	Y24										
D4565	Weight changing display	Default: K0; setting range: K0 ~ K32767	R/W	⊙	K0								
D4566	Status of Y point	Work with X and Y points K0: Y point output enabled (default) K1: Y point output closed K2: Y point output on hold	R/W	X	K0								
D4567	Y20 weight output setting value (Low word)	When the weight is greater than the weight value that is set to output, you can set the Y point output to ON or OFF.	R/W	⊙	K0								
D4568	Y20 weight output setting value (High word)		R/W	⊙	K0								
D4569	Y21 weight output setting value (Low word)		R/W	⊙	K0								
D4570	Y21 weight output setting value (High word)		R/W	⊙	K0								
D4571	Y22 weight output setting value (Low word)		R/W	⊙	K0								
D4572	Y22 weight output setting value (High word)		R/W	⊙	K0								
D4573	Y23 weight output setting value (Low word)		R/W	⊙	K0								
D4574	Y23 weight output setting value (High word)		R/W	⊙	K0								
D4575	Y24 weight output setting value (Low word)		R/W	⊙	K0								

Special D	Item	Description	Attributes		Default
D4576	Y24 weight output setting value (High word)		R/W	⊙	K0
D4577	Y25 weight output setting value (Low word)		R/W	⊙	K0
D4578	Y25 weight output setting value (High word)		R/W	⊙	K0
D4579	Y26 weight output setting value (Low word)		R/W	⊙	K0
D4580	Y26 weight output setting value (High word)		R/W	⊙	K0
D4581	Y27 weight output setting value (Low word)		R/W	⊙	K0
D4582	Y27 weight output setting value (High word)		R/W	⊙	K0
D4583	Y20 delay output time		Default: K0; setting range: K0 ~ K300; unit: 10 ms	R/W	⊙
D4584	Y21 delay output time	R/W		⊙	K0
D4585	Y22 delay output time	R/W		⊙	K0
D4586	Y23 delay output time	R/W		⊙	K0
D4587	Y24 delay output time	R/W		⊙	K0
D4588	Y25 delay output time	R/W		⊙	K0
D4589	Y26 delay output time	R/W		⊙	K0
D4590	Y27 delay output time	R/W		⊙	K0
D4591	Current output mode	Weight value corresponding to a current output K0: disable (default) K1: IO1 weight value of the channel corresponding to a current output	R/W	⊙	K0
D4600	Commands (ICT / for calibration)	Write H'5678: to write the data into Flash and then the data is retentive after power-off. Write H'55AA: reset to defaults and to write the defaults into Flash and then the data is retentive after power-off. Write H'AA00: disable the calibration mode Write H'AA01: enable the calibration mode Message: H'FFFF: failed to execute the instruction H'AAAA: succeed to execute the instruction	R/W	X	H'0
D4601	Calibrated weight 1 (Lo)	Calibrated weight of the zero point	R/W	⊙	K0
D4602	Calibrated weight 1 (Hi)		R/W	⊙	
D4603	Calibrated weight 2 (Lo)	Calibrated weight of the calibration point 2	R/W	⊙	K100
D4604	Calibrated weight 2 (Hi)		R/W	⊙	
D4605	Calibrated weight 3 (Lo)	Calibrated weight of the calibration point 3	R/W	⊙	K200

Special D	Item	Description	Attributes		Default
D4606	Calibrated weight 3 (Hi)		R/W	⊙	
D4607	Calibrated weight 4 (Lo)	Calibrated weight of the calibration point 4	R/W	⊙	K300
D4608	Calibrated weight 4 (Hi)		R/W	⊙	
D4609	Calibrated weight 5 (Lo)	Calibrated weight of the calibration point 5	R/W	⊙	K400
D4610	Calibrated weight 5 (Hi)		R/W	⊙	
D4611	Calibrated weight 6 (Lo)	Calibrated weight of the calibration point 6	R/W	⊙	K500
D4612	Calibrated weight 6 (Hi)		R/W	⊙	
D4613	Calibrated weight 7 (Lo)	Calibrated weight of the calibration point 7	R/W	⊙	K600
D4614	Calibrated weight 7 (Hi)		R/W	⊙	
D4615	Calibrated weight 8 (Lo)	Calibrated weight of the calibration point 8	R/W	⊙	K700
D4616	Calibrated weight 8 (Hi)		R/W	⊙	
D4617	Calibrated weight 9 (Lo)	Calibrated weight of the calibration point 9	R/W	⊙	K800
D4618	Calibrated weight 9 (Hi)		R/W	⊙	
D4619	Calibrated weight 10 (Lo)	Calibrated weight of the calibration point 10	R/W	⊙	K900
D4620	Calibrated weight 10 (Hi)		R/W	⊙	
D4621	Calibrated weight 11 (Lo)	Calibrated weight of the calibration point 11	R/W	⊙	K1000
D4622	Calibrated weight 11 (Hi)		R/W	⊙	
D4623	Calibrated weight 12 (Lo)	Calibrated weight of the calibration point 12	R/W	⊙	K1100
D4624	Calibrated weight 12 (Hi)		R/W	⊙	
D4625	Calibrated weight 13 (Lo)	Calibrated weight of the calibration point 13	R/W	⊙	K1200
D4626	Calibrated weight 13 (Hi)		R/W	⊙	
D4627	Calibrated weight 14 (Lo)	Calibrated weight of the calibration point 14	R/W	⊙	K1300
D4628	Calibrated weight 14 (Hi)		R/W	⊙	
D4629	Calibrated weight 15 (Lo)	Calibrated weight of the calibration point 15	R/W	⊙	K1400
D4630	Calibrated weight 15 (Hi)		R/W	⊙	
D4631	Calibrated weight 16 (Lo)	Calibrated weight of the calibration point 16	R/W	⊙	K1500
D4632	Calibrated weight 16 (Hi)		R/W	⊙	
D4633	Calibrated weight 17 (Lo)	Calibrated weight of the calibration point 17	R/W	⊙	K1600
D4634	Calibrated weight 17 (Hi)		R/W	⊙	
D4635	Calibrated weight 18 (Lo)	Calibrated weight of the calibration point 18	R/W	⊙	K1700
D4636	Calibrated weight 18 (Hi)		R/W	⊙	
D4637	Calibrated weight 19 (Lo)	Calibrated weight of the calibration point 19	R/W	⊙	K1800
D4638	Calibrated weight 19 (Hi)		R/W	⊙	
D4639	Calibrated weight 20 (Lo)	Calibrated weight of the calibration point 20	R/W	⊙	K1900
D4640	Calibrated weight 20 (Hi)		R/W	⊙	

Special D	Item	Description	Attributes		Default
D4641	Raw data 1 (Lo)	Raw data of the zero point	R/W	⊙	K0
D4642	Raw data 1 (Hi)		R/W	⊙	
D4643	Raw data 2 (Lo)	Raw data of the calibration point 2	R/W	⊙	K1000
D4644	Raw data 2 (Hi)		R/W	⊙	
D4645	Raw data 3 (Lo)	Raw data of the calibration point 3	R/W	⊙	K2000
D4646	Raw data 3 (Hi)		R/W	⊙	
D4647	Raw data 4 (Lo)	Raw data of the calibration point 4	R/W	⊙	K3000
D4648	Raw data 4 (Hi)		R/W	⊙	
D4649	Raw data 5 (Lo)	Raw data of the calibration point 5	R/W	⊙	K4000
D4650	Raw data 5 (Hi)		R/W	⊙	
D4651	Raw data 6 (Lo)	Raw data of the calibration point 6	R/W	⊙	K5000
D4652	Raw data 6 (Hi)		R/W	⊙	
D4653	Raw data 7 (Lo)	Raw data of the calibration point 7	R/W	⊙	K6000
D4654	Raw data 7 (Hi)		R/W	⊙	
D4655	Raw data 8 (Lo)	Raw data of the calibration point 8	R/W	⊙	K7000
D4656	Raw data 8 (Hi)		R/W	⊙	
D4657	Raw data 9 (Lo)	Raw data of the calibration point 9	R/W	⊙	K8000
D4658	Raw data 9 (Hi)		R/W	⊙	
D4659	Raw data 10 (Lo)	Raw data of the calibration point 10	R/W	⊙	K9000
D4660	Raw data 10 (Hi)		R/W	⊙	
D4661	Raw data 11 (Lo)	Raw data of the calibration point 11	R/W	⊙	K10000
D4662	Raw data 11 (Hi)		R/W	⊙	
D4663	Raw data 12 (Lo)	Raw data of the calibration point 12	R/W	⊙	K11000
D4664	Raw data 12 (Hi)		R/W	⊙	
D4665	Raw data 13 (Lo)	Raw data of the calibration point 13	R/W	⊙	K12000
D4666	Raw data 13 (Hi)		R/W	⊙	
D4667	Raw data 14 (Lo)	Raw data of the calibration point 14	R/W	⊙	K13000
D4668	Raw data 14 (Hi)		R/W	⊙	
D4669	Raw data 15 (Lo)	Raw data of the calibration point 15	R/W	⊙	K14000
D4670	Raw data 15 (Hi)		R/W	⊙	
D4671	Raw data 16 (Lo)	Raw data of the calibration point 16	R/W	⊙	K15000
D4672	Raw data 16 (Hi)		R/W	⊙	
D4673	Raw data 17 (Lo)	Raw data of the calibration point 17	R/W	⊙	K16000
D4674	Raw data 17 (Hi)		R/W	⊙	
D4675	Raw data 18 (Lo)	Raw data of the calibration point 18	R/W	⊙	K17000

5

Special D	Item	Description	Attributes		Default
D4676	Raw data 18 (Hi)		R/W	⊙	
D4677	Raw data 19 (Lo)	Raw data of the calibration point 19	R/W	⊙	K18000
D4678	Raw data 19 (Hi)		R/W	⊙	
D4679	Raw data 20 (Lo)	Raw data of the calibration point 20	R/W	⊙	K19000
D4680	Raw data 20 (Hi)		R/W	⊙	
D4681	Number of the calibration points	Setting range: K2 ~ K20	R/W	⊙	K2
D4682	Commands for calibrations	Setting range: K1 ~ K20 Once the setting is done, the status switches back to ON.	R/W	⊙	K0

MEMO