

# Ruijie RG-AP820-L(V3) Access Point

## Hardware Installation and Reference Guide

## Copyright

Ruijie Networks©2023

Ruijie Networks reserves all copyrights of this document.

Any reproduction, excerpt, backup, modification, transmission, translation or commercial use of this document or any portion of this document, in any form or by any means, without the prior written consent of Ruijie Networks is prohibited.

Trademarks including  ,  and  are owned by Ruijie Networks.

All other trademarks or registered trademarks mentioned in this document are owned by their respective owners.

## Disclaimer

The products, services or features you purchase are subject to commercial contracts and terms. Some or all of the products, services or features described in this document may not be within the scope of your purchase or use. Unless otherwise agreed in the contract, Ruijie Networks does not make any express or implied statement or guarantee for the content of this document.

Due to product version upgrades or other reasons, the content of this document will be updated from time to time. Ruijie Networks reserves the right to modify the content of the document without any notice or prompt.

This manual is for reference only. Ruijie Networks endeavors to ensure content accuracy and will not shoulder any responsibility for losses and damages caused due to content omissions, inaccuracies or errors.

# Preface

## Intended Audience

This document is intended for:

- Network engineers
- Technical support and servicing engineers
- Network administrators

## Technical Support

- Ruijie Networks Website: <https://www.ruijienetworks.com/>
- Technical Support Website: <https://ruijienetworks.com/support>
- Case Portal: <https://caseportal.ruijienetworks.com>
- Community: <https://community.ruijienetworks.com>
- Technical Support Email: [service\\_rj@ruijienetworks.com](mailto:service_rj@ruijienetworks.com)
- Live Chat: <https://www.ruijienetworks.com/rita>

## Conventions

### 1. Signs

The symbols used in this document are described as follows:

#### **Danger**

An alert that calls attention to safety operation instructions that if not understood or followed when operating the device can result in physical injury.

---

#### **Warning**

An alert that calls attention to important rules and information that if not understood or followed can result in data loss or equipment damage.

---

#### **Caution**

An alert that calls attention to essential information that if not understood or followed can result in function failure or performance degradation.

---

---

** Note**

An alert that contains additional or supplementary information that if not understood or followed will not lead to serious consequences.

---

---

** Specification**

An alert that contains a description of product or version support.

---

## **2. Note**

This manual provides the device installation steps, hardware troubleshooting, module technical specifications, and specifications and usage guidelines for cables and connectors. It is intended for the users who have some experience in installing and maintaining network hardware. At the same time, it is assumed that the users are already familiar with the related terms and concepts.

# Contents

Preface.....	I
1 Product Overview .....	1
1.1 Appearance.....	1
1.2 Package Contents.....	3
1.3 Technical Specifications.....	3
1.3.1 Size and Weight .....	3
1.3.2 RF .....	4
1.3.3 Ports .....	6
1.3.4 Power Supply .....	6
1.3.5 Environment and Reliability .....	6
1.4 LEDs and Button.....	7
1.5 SFP Modules .....	8
2 Preparing for Installation.....	10
2.1 Safety Precautions.....	10
2.1.1 General Safety Precautions .....	10
2.1.2 Handling Safety .....	10
2.1.3 Electric Safety.....	11
2.2 Installation Environment Requirements .....	11
2.2.1 Bearing Requirements .....	11
2.2.2 Ventilation Requirements.....	12

2.2.3 Space Requirement .....	12
2.2.4 Temperature/Humidity Requirements.....	12
2.2.5 Cleanliness Requirements .....	12
2.2.6 Anti-interference Requirements .....	14
2.2.7 Lightning Protection Requirements .....	14
2.2.8 Inspection of the Installation Site .....	14
2.3 Tools .....	15
3 Installing the Access Point .....	17
3.1 Installation Flowchart .....	17
3.2 Before You Begin.....	17
3.3 Precautions .....	19
3.4 Installing the Access Point.....	19
3.4.1 Ceiling Mounting .....	19
3.4.2 Wall Mounting .....	21
3.5 Securing the Access Point.....	23
3.6 Installing the SFP Module.....	23
3.7 Removing the Access Point .....	24
3.8 Connecting Cables .....	25
3.9 Bundling Cables.....	26
3.9.1 Precautions .....	26
3.9.2 Bundling Steps.....	26

3.10 Checking after Installation .....	26
3.10.1 Checking Cable Connection .....	26
3.10.2 Checking Power Supply .....	26
4 Verifying Operating Status .....	27
4.1 (Optional) Configuring the Environment .....	27
4.2 Powering up the AP.....	27
4.2.1 Checking Environment before Power-on.....	27
4.2.2 Checking Environment after Power-on.....	27
5 Monitoring and Maintenance.....	28
5.1 Monitoring.....	28
5.1.1 LED.....	28
5.1.2 CLI Commands .....	28
5.2 Remote Maintenance.....	28
5.3 Hardware Maintenance .....	28
6 Troubleshooting .....	29
6.1 Troubleshooting Flowchart .....	29
6.2 Troubleshooting.....	29
6.2.1 LED does not light up after the AP is powered on .....	29
6.2.2 Ethernet port is not working after the Ethernet cable is plugged in.....	30
6.2.3 Wireless client cannot find the AP .....	30
6.2.4 LED keeps blinking red .....	30

6.2.5 LED keeps blinking green .....	30
6.2.6 LED keeps blinking orange (Fit AP mode) .....	30
6.2.7 LED does not turn solid blue or blinking blue .....	30
7 Appendix .....	32
7.1 Connectors and Media.....	32
7.2 Mini-GBIC Modules .....	34
7.3 Cabling Recommendations .....	35
7.4 Power Supply.....	39



# 1 Product Overview

The RG-AP820-L(V3) AP is a dual-band dual-radio access point compliant with the IEEE 802.11ax standard. The RG-AP820-L(V3) AP provides a combined data rate of 2.975 Gbps, with up to 575 Mbps in the 2.4 GHz band and 2.4 Gbps in the 5 GHz band. Designed for flexible deployments in the field of education, government, finance and business, the RG-AP820-L(V3) AP offers one combo port.

## 1.1 Appearance

The RG-AP820-L(V3) provides two radio frequency (RF) connectors, one 10/100/1000 BASE-T Ethernet port, one 2.5G SFP port, one Console port and one DC power plug. The AP supports PoE or DC power supply.

**Figure 1-1 Appearance**

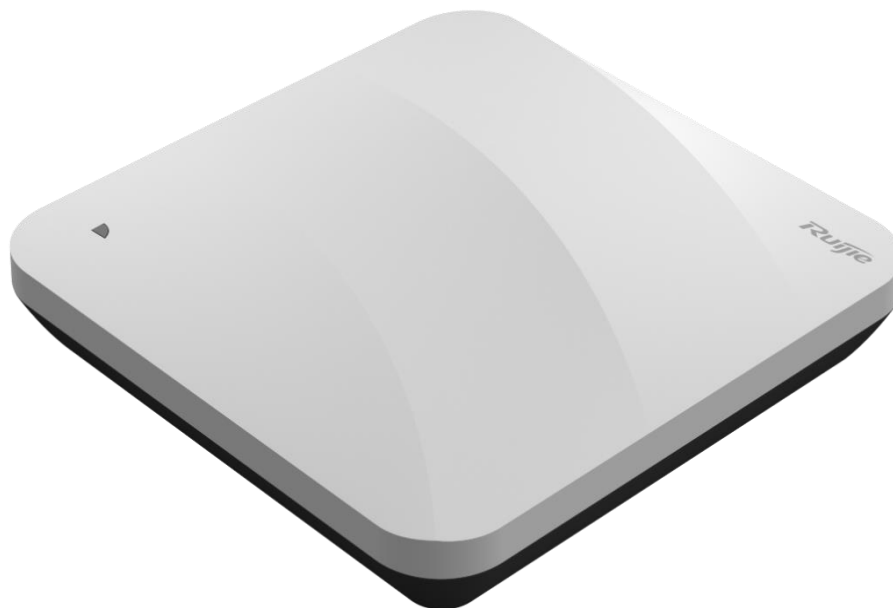

**Figure 1-2 Front Panel**



**Table 1-1 Front Panel**

No.	Item	Description
1	LED	Indicate the operation status of device.

**Figure 1-3 Side View**

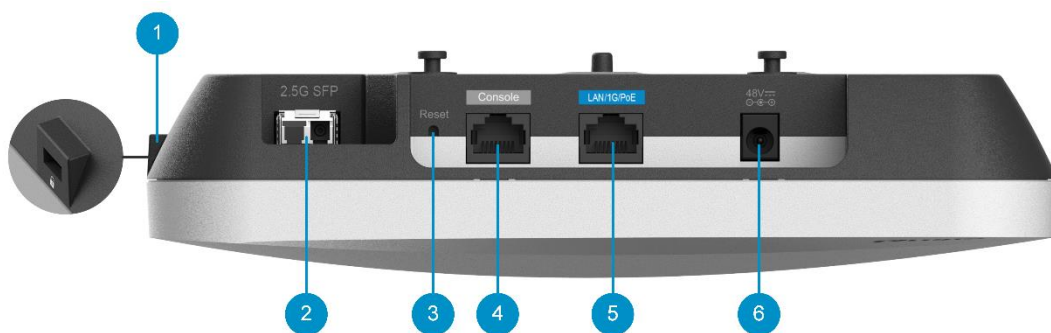

**Table 1-2 Side View**

No.	Button and Port	Description
-----	-----------------	-------------

1	Anti-theft lock hole	Connect to the anti-theft lock.
2	2.5G SFP port	The uplink SFP port for service data transmission.
3	Reset button	Reboot the device or restore the device to factory settings.
4	Console port	Connect to the device that is managed with the serial cable.
5	1000 BASE-T Ethernet port	The uplink adaptive Ethernet port for service data transmission. Support IEEE 802.3af standard PoE power supply.
6	DC power plug	Connect to the DC power adapter to supply power to the AP.

## 1.2 Package Contents

**Table 1-3 Package Contents**

Item	Quantity
RG-AP820-L(V3) Access Point	1
Mounting Bracket	1
Wall Anchor	2
Phillips Pan Head Screws M4 x 20	4
Warranty Card	1
Installation Guide	1

## 1.3 Technical Specifications

### 1.3.1 Size and Weight

**Table 1-4 Size and Weight**

Item	Parameter
<b>Main Unit Dimensions (W x D x H)</b>	220 mm × 220 mm × 49 mm (8.66 in. x 8.66 in. x 1.93 in.)
<b>Weight</b>	Main Unit: 0.6 kg (1.32 lbs.) Bracket: 0.2 kg (0.44 lbs.)

<b>Mounting</b>	Ceiling/wall mount capable
<b>Anti-theft Lock</b>	Kensington lock Security screw
<b>Bracket Dimensions (W x D x H)</b>	120 mm×120 mm×8 mm (4.72 in. x 4.72 in. x 0.31 in.)
<b>Mounting Hole Pattern</b>	53 mm (2.09 in.) x 53 mm (2.09 in.)
<b>Mounting Hole Diameter</b>	6.5 mm (0.26 in.)

### 1.3.2 RF

Table 1-5 RF

Item	Parameter
<b>RF Design</b>	Dual-radio Radio1: 2.4 GHz, 2×2 MU-MIMO (2 spatial streams) Radio2: 5 GHz, 2×2 MU-MIMO (2 spatial streams) Combined dual-band:4 spatial streams
<b>Operating Frequency</b>	Radio1: 802.11b/g/n/ax, 2.4 GHz-2.4835 GHz, HE40 Radio2: 802.11a/n/ac/ax, 5.150 GHz-5.350 GHz, HE80/HE160 802.11a/n/ac, 5.470 GHz-5.725 GHz, 5.725 GHz-5.850 GHz, HE80 (country-specific restrictions apply)
<b>Max. Data Rate</b>	Radio1: 2.4 GHz, 575 Mbps Radio2: 5 GHz, 2.4 Gbps Combined dual-band: 2.975Gbps

<b>Antenna Type</b>	Built-in omnidirectional antenna
<b>Antenna Gain</b>	2.4 GHz: 3 dBi 5 GHz: 3 dBi
<b>Max. Transmit Power</b>	20 dBm (country-specific restrictions apply)
<b>Transmit Power Adjustment</b>	Configurable in increments of 1 dBm
<b>Modulation</b>	OFDM: BPSK@6/9Mbps, QPSK@12/18Mbps, 16-QAM@24Mbps, 64-QAM@48/54Mbps DSSS: DBPSK@1Mbps, DQPSK@2Mbps, and CCK@5.5/11Mbps MIMO-OFDM: BPSK, QPSK, 16QAM, 64QAM, 256QAM and 1024QAM OFDMA
<b>Receive Sensitivity</b>	11b: -96dBm(1Mbps), -93dBm(5Mbps), -89dBm(11Mbps) 11a/g: -91dBm(6Mbps), -85dBm(24Mbps), -80dBm(36Mbps), -74dBm(54Mbps) 11n: -90dBm@MCS0, -70dBm@MCS7, -89dBm@MCS8, -68dBm@MCS15 11ac: HT20: -88dBm(MCS0), -63dBm(MCS9) 11ac: HT40: -85dBm(MCS0), -60dBm(MCS9) 11ac: HT80: -82dBm(MCS0), -57dBm(MCS9) 11ax: HE80: -82dBm(MCS0), -57dBm(MCS9), -52dBm(MCS11) 11ax: 160MHz: -77dBm(MCS0), -50dBm(MCS11)
<b>Wi-Fi Coverage Radius</b>	10 m (32.81 feet.) Note: The Wi-Fi coverage is related to the installation environment of the access point.

### 1.3.3 Ports

**Table 1-6 Ports**

Item	Description
<b>Bluetooth</b>	Bluetooth 5.1
<b>Fixed Service Port</b>	One 10/100/1000 Base-T Ethernet port (IEEE 802.3af-compliant PoE) One 2.5G SFP port (conformity to 1G SFP port)
<b>Fixed Management Port</b>	One RJ45 Console port
<b>LED</b>	One system status LED
<b>Button</b>	One reset button

### 1.3.4 Power Supply

**Table 1-7 Power Supply**

Item	Description
<b>Power Supply</b>	DC power adapter: 48 V/0.6 A (Optional. Please refer to Power Supply for more details.) PoE: IEEE 802.3af-compliant
<b>Max. Power Consumption</b>	12.95 W

---

 **Caution**

The power adapter is optional. If you need to use a DC power adapter for power supply, please purchase an adapter that meets the corresponding safety requirements.

---

### 1.3.5 Environment and Reliability

**Table 1-8 Environment and Reliability**

Item	Description
------	-------------

<b>Temperature</b>	<p>Operating: -10°C to+ 50°C (14°F to 122°F)</p> <p>Storage: -40°C to+ 70°C (-40°F to +158°F)</p> <p>At a height between 3000 m (9842.52 ft.) to 5000 m (16404.20 ft.) above the sea level, every time the altitude increases by 220 m (721.78 ft.), the maximum temperature decreases by 1°C (1.8°F).</p>
<b>Humidity</b>	<p>Operating: 0% to 95% (RH), non-condensing</p> <p>Storage: 0% to 95% (RH), non-condensing)</p>
<b>Safety Certifications</b>	GB 4943.1, IEC 62368-1
<b>EMC Certifications</b>	EN 300386, GB/T 19286, GB/T 17618

## 1.4 LEDs and Button

**Table 1-9 Fit AP**

State	Frequency	Meaning
Off	N/A	The AP is NOT receiving power or the AP is in Do Not Disturb mode, which can be disabled by software.
Blinking green	3Hz	uBoot program initialization is in progress.
Solid green	N/A	Main program initialization is in progress.
Blinking red	3Hz	Initialization is complete, but no Ethernet activity.
	2Hz	Locate the AP.
Solid orange	N/A	Initialization is complete, and the AP is establishing a CAPWAP connection with an AC.
Blinking orange	3Hz	Firmware upgrade in progress. Do not power off the AP.
Solid blue	N/A	Normal operation, but no wireless clients are associated with the AP.
Blinking blue	3Hz	Normal operation, and at least one wireless client is associated with the AP.
Reset button	Pressed for less than 2s	Reboot the device.
	Pressed for more than 3s	Restore default settings.

**Table 1-10 Fat AP**

State	Frequency	Meaning
Off	N/A	The AP is NOT receiving power. Or the AP is in Do Not Disturb mode, which can be disabled by software.
Blinking green	3Hz	uBoot program initialization is in progress.
Solid green	N/A	Main program initialization is in progress.
Blinking red	3Hz	Initialization is complete, but no Ethernet activity.
Solid blue	N/A	Normal operation, but no wireless clients are associated with the AP.
Blinking blue	3Hz	Normal operation, and at least one wireless client is associated with the AP.
Reset button	Pressed for less than 2s	Reboot the device.
	Pressed for more than 3s	Restore default settings.

## 1.5 SFP Modules

The 2.5G SFP port of the AP supports both copper and fiber links. The negotiation speed may vary with the SFP module type and the speeds on both sides of the link.

**Table 1-11 Negotiation Speed When Connected with SFP Port on Peer Device**

AP SFP Port Speed	SFP Fiber Module Speed	Negotiation Speed		
		1 Gbps	1 Gbps/10 Gbps/Auto	1 Gbps/2.5 Gbps/10 Gbps/Auto
1 Gbps	3 Gbps	1 Gbps	1 Gbps	1 Gbps
1 Gbps	1 Gbps	1 Gbps	1 Gbps	1 Gbps
2.5 Gbps	3 Gbps	Not supported	Not supported	2.5 Gbps
2.5 Gbps	1 Gbps	Not supported	Not supported	2.5 Gbps



**Table 1-12 Negotiation Speed When Connected with Copper Port on Peer Device**

AP SFP Port Speed	SFP Copper Module Speed	Negotiation Speed		
		1 Gbps	1 Gbps/10 Gbps/Auto	1 Gbps/2.5 Gbps/10 Gbps/Auto
1 Gbps	2.5 Gbps	Not supported	Not supported	Not supported
1 Gbps	1 Gbps	1 Gbps	1 Gbps	1 Gbps
2.5 Gbps	2.5 Gbps	Not supported	Not supported	2.5 Gbps
2.5 Gbps	1 Gbps	Not supported	Not supported	Not supported

---

**⚠ Caution**

- The 2.5G SFP port of the AP does not support speed negotiation. When you use the transceiver module, the speed of the AP, the module, and the port of peer device must be the same.
  - The SFP port and copper port can be multiplexed as a combo port. If two ports are connected with cables at the same time, AP will preferentially select the SFP port for data transmission (the copper port is automatically disabled). When the cable of SFP port is unplugged, the copper port is automatically enabled.
-

# 2 Preparing for Installation

## 2.1 Safety Precautions

---

**Note**

- To avoid personal injury and device damage, carefully read the safety precautions before you install the device.
  - The following safety precautions may not cover all possible dangers.
- 

### 2.1.1 General Safety Precautions

- Do not expose the AP to high temperature, dusts, or harmful gases.
- Do not install the AP in an inflammable or explosive environment.
- Keep the AP away from EMI sources such as large radar stations, radio stations, and substations.
- Do not subject the AP to unstable voltage, vibration, and noises.
- The installation site should be free from water flooding, seepage, dripping, or condensation. The installation site should be selected according to network planning and communications equipment features, and considerations such as climate, hydrology, geology, earthquake, electrical power, and transportation.
- Keep the AP at least 500 meters away from the ocean and do not face it towards the sea breeze.
- Do not place the device in walking areas.
- During the installation and maintenance, do not wear loose clothes, ornaments, or any other things that may be hooked by the chassis.
- Keep tools and components away from walking areas.

### 2.1.2 Handling Safety

- Prevent the device from being frequently handled.
- Cut off all the power supplies and unplug all power cords before moving or handling the device.

### 2.1.3 Electric Safety

---

**! Warning**

- Improper or incorrect electric operations may cause a fire, electric shock, and other accidents, and lead to severe and fatal personal injury and device damage.
  - Direct or indirect contact with high voltage or mains power supply via wet objects may cause fatal dangers.
- 

- Observe local regulations and specifications during electric operations. Only personnel with relevant qualifications can perform such operations.
- Check whether there are potential risks in the work area. For example, check whether the power supply is grounded, whether the grounding is reliable, and whether the ground is wet.
- Learn about the position of the indoor emergency power switch before installation. Cut off the power switch in case of accidents.
- Check the device carefully before shutting down the power supply.
- Do not place the device in a damp/wet location. Do not let any liquid enter the chassis.
- Keep the device far away from grounding or lightning protection devices for power equipment.
- Keep the device away from radio stations, radar stations, high-frequency high-current devices, and microwave ovens.

## 2.2 Installation Environment Requirements

Install the device indoors to ensure its normal operation and prolonged service life.

The installation site must meet the following requirements.

### 2.2.1 Bearing Requirements

Evaluate the weight of the device and its accessories (for example, the bracket and power supply modules), and ensure that the ground of the installation site meets the requirements.

## 2.2.2 Ventilation Requirements

Reserve sufficient space in front of the air vents to ensure normal heat dissipation. After various cables are connected, bundle the cables or place them in the cable management bracket to avoid blocking air inlets.

## 2.2.3 Space Requirement

Maintain a minimum clearance of 0.4 cm (15.75 in.) around the device to ensure proper cooling and ventilation.

## 2.2.4 Temperature/Humidity Requirements

To ensure the normal operation and prolonged service life of the device, maintain an appropriate temperature and humidity in the equipment room.

The equipment room with too high or too low temperature and humidity for a long period may damage the device.

- In an environment with high humidity, the insulating material may have poor insulation or even leak electricity.
- In an environment with low humidity, the insulating strip may dry and shrink, loosening screws.
- In a dry environment, static electricity is prone to occur and damage the internal circuits of the device.
- Too high temperatures can accelerate the aging of insulation materials, greatly reducing the reliability of the device and severely affecting its service life.

---

### Note

The ambient temperature and humidity of the device are measured at the point that is 1.5 m (59.06 in.) above the floor and 0.4 m (15.75 in.) before the device when there is no protective plate in front or at the back of the device.

---

## 2.2.5 Cleanliness Requirements

Dust poses a major threat to the device. The indoor dust takes on a positive or negative static electric charge when falling on the device, causing poor contact of the metallic joint. Such electrostatic adhesion may occur more easily when the relative humidity is low, not only affecting the service life of the device, but also causing communication

faults. Table 2-1 describes the requirements for the dust content and granularity in the equipment room.

**Table 2-1 Requirements for Dust**

Dust	Unit	Content
Dust particles (diameter $\leq 0.5 \mu\text{m}$ )	Particles/m <sup>3</sup>	$\leq 1.4 \times 10^7$
Dust particles ( $0.5 \mu\text{m} \leq \text{diameter} \leq 1 \mu\text{m}$ )	Particles/m <sup>3</sup>	$\leq 7 \times 10^5$
Dust particles ( $1 \mu\text{m} \leq \text{diameter} \leq 3 \mu\text{m}$ )	Particles/m <sup>3</sup>	$\leq 2.4 \times 10^5$
Dust particles ( $3 \mu\text{m} \leq \text{diameter} \leq 1 \mu\text{m}$ )	Particles/m <sup>3</sup>	$\leq 1.3 \times 10^5$

Apart from dust, the salt, acid, and sulfide in the air in the equipment room must meet strict requirements. These harmful substances will accelerate metal corrosion and component aging. Therefore, the equipment room should be properly protected against the intrusion of harmful gases, such as sulfur dioxide, hydrogen sulfide, nitrogen dioxide, and chlorine gas. Table 2-2 lists limit values for harmful gases.

**Table 2-2 Requirements for Gases**

Gas	Average (mg/m <sup>3</sup> )	Maximum (mg/m <sup>3</sup> )
Sulfur dioxide (SO <sub>2</sub> )	0.2	1.5
Hydrogen sulfide (HS)	0.006	0.03
Nitrogen dioxide (NO <sub>2</sub> )	0.04	0.15
Ammonia gas (NH <sub>3</sub> )	0.05	0.15
Chlorine gas (Cl <sub>2</sub> )	0.01	0.3

---

**Note**

**Average** refers to the average value of harmful gases measured in one week. **Maximum** refers to the upper limit of harmful gases measured in one week, and the maximum value lasts up to 30 minutes every day.

---

## 2.2.6 Anti-interference Requirements

- Take interference prevention measures for the power supply system.
- Keep the device away from the grounding equipment or lightning and grounding equipment of the power device as much as possible.
- Keep the device far away from high-frequency current devices such as high-power radio transmitting station and radar launcher.
- Take electromagnetic shielding measures when necessary.

## 2.2.7 Lightning Protection Requirements

The device can guard against lightning strikes. As an electric device, it may still be damaged by strong lightning strikes. Take the following lightning protection measures:

- Ensure that the neutral point of the AC power socket is in good contact with the ground.
- You are advised to install a power lightning arrester in front of the power input end to enhance the lightning prevention for the power supply.

## 2.2.8 Installation Site Requirements

Regardless of whether the device is installed on the wall or ceiling, the following conditions must be met:

- Maintain a minimum clearance of 0.4 cm (15.75 in.) around the device to ensure proper cooling and ventilation.
- The installation site allows for proper cooling and ventilation. You are advised to install an air conditioner if you want to install the device in a hot area.
- The installation side is sturdy enough to support the weight of the device and its accessories.

## 2.3 Federal Communications Commission Statement

This equipment has been tested and found to comply with the limits for a Class B digital device, pursuant to part 15 of the FCC Rules. These limits are designed to provide reasonable protection against harmful interference in a residential installation. This equipment generates, uses and can radiate radio frequency energy and, if not installed and used in accordance with the instructions, may cause harmful interference to radio communications. However, there is no guarantee that interference will not occur in a particular installation. If this equipment does cause harmful interference to radio or television reception, which can be determined by turning the equipment off and on, the user is encouraged to try to correct the interference by one or more of the following measures:

- Reorient or relocate the receiving antenna.
- Increase the separation between the equipment and receiver.
- Connect the equipment into an outlet on a circuit different from that to which the receiver is connected.
- Consult the dealer or an experienced radio/TV technician for help.

This device complies with Part 15 of the FCC Rules. Operation is subject to the following two conditions:

(1) this device may not cause harmful interference.

(2) this device must accept any interference received, including interference that may cause undesired operation.

### **RF Exposure Warning!**

This equipment must be installed and operated in accordance with provided instructions and the antenna(s) used for this transmitter must be installed to provide a separation distance of at least 20 cm from all persons and must not be co-located or operating in conjunction with any other antenna or transmitter.

### **Caution!**

Any changes or modifications not expressly approved by the party responsible for compliance could void the user's authority to operate the equipment.

### **IMPORTANT!**

Operation in the band 5150-5250 MHz is only for indoor use.

## 2.4 Tools

**Table 2-3 Tools**

<b>Common Tools</b>	Phillips screwdrivers, wires, Ethernet cable, fastening bolts, diagonal pliers, and binding straps
<b>Special Tools</b>	Antistatic gloves, wire stripper, crimping pliers, crystal connector crimping pliers, and wire cutter
<b>Meter</b>	Multimeter, and bit error rate tester (BERT)
<b>Relevant Devices</b>	PC, display, and keyboard

---

**Note**

The device is delivered without a tool kit. The tool kit and cables are customer-supplied.

---



# 3 Installing the Access Point

The RG-AP820-L(V3) AP must be fixed and installed indoors.

---

**⚠ Caution**

Before installing the device, make sure you have carefully read the requirements described in Chapter 2.

---

## 3.1 Installation Flowchart

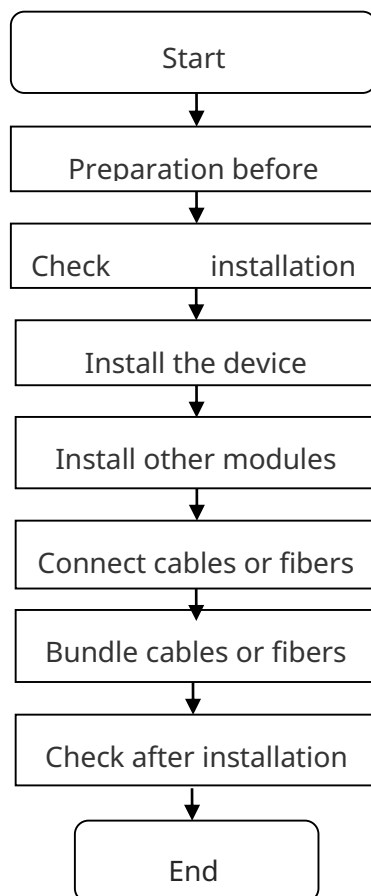

## 3.2 Before You Begin

Before you install the device, verify that all the parts in the package contents are there and make sure that:

- The installation position provides sufficient space for heat dissipation.
- The installation position meets the temperature and humidity requirements of the device.
- The power supply and required current are available in the installation position.
- The Ethernet cable have been deployed in the installation position.
- The selected power supply modules meet the system power requirements.
- The position of the indoor emergency power switch is learned before installation. The power switch is cut off in case of accidents.
- For ceiling-mounted or wall-mounted AP, the mounting bracket size, mounting hole pattern and diameter should meet the requirements in **Table 1-4**.

**Figure 3-1 Mounting Bracket**

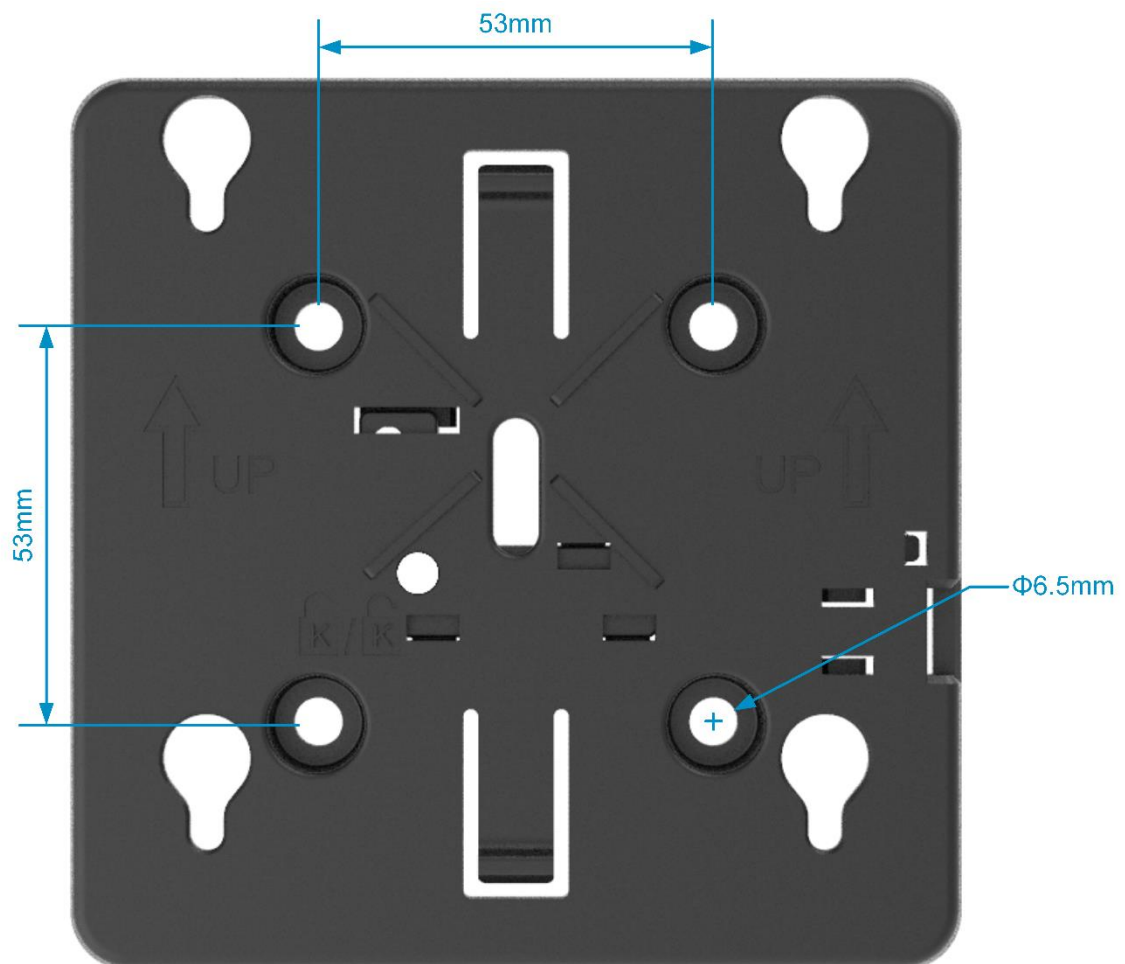

### 3.3 Precautions

To avoid damage to the AP, observe the following safety precautions:

- Do not power on the device during installation.
- Install the device in a well-ventilated location.
- Do not subject the device to high temperatures.
- Keep away from high voltage cables.
- Install the device indoors.
- Do not expose the device in a thunderstorm or strong electric field.
- Keep the device clean and dust-free.
- Disconnect the device before cleaning it.
- Do not wipe the device with a damp cloth.
- Do not wash the device with liquid.
- Do not open the enclosure when the device is working.
- Fasten the device tightly.

### 3.4 Installing the Access Point

---

 **Note**

- **You are advised to install the device where you can get the optimal coverage.**
  - In the indoor area, the signal coverage of the ceiling-mounted device is larger than that of the wall-mounted device. Please choose the ceiling-mounting method first.
- 

#### 3.4.1 Ceiling Mounting

- (1) Drill four 6.5 mm (0.26 in.) diameter holes in the ceiling, 53 mm (2.09 in.) apart. Tap wall anchors into the holes, and drive screws through the mounting bracket into the anchors to secure the bracket.

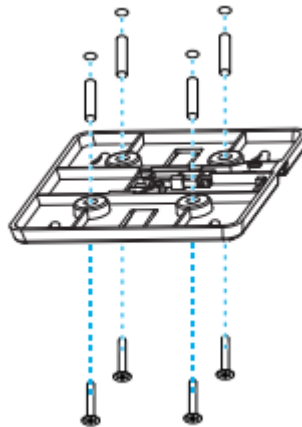
**Figure 3-2 Attaching the Mounting Bracket to the Ceiling**

(2) Align the square feet on the rear of the AP with the mounting holes on the bracket.

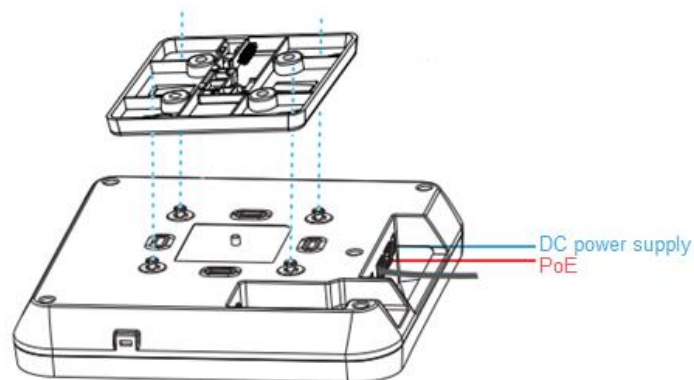
**Figure 3-3 Aligning the Square Feet with the Mounting Holes**

---

**⚠ Caution**

Install the Ethernet cables before mounting the AP on the bracket.

---

(3) Slide the AP onto the bracket in the opposite direction of the arrow on the mounting bracket until it clicks into place.

**Figure 3-4 Mounting the AP on the Bracket**

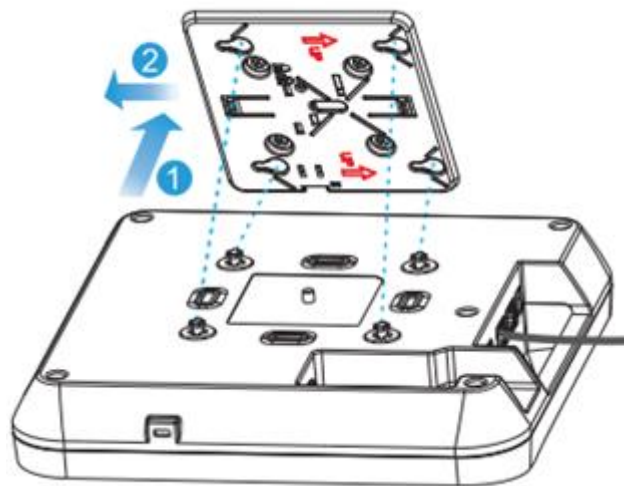

---

**⚠ Caution**

- The AP can be installed in any of four directions on the mounting bracket depending on how you route the Ethernet cable.
  - The square feet should fit easily into the mounting slots. Do not forcibly push the AP into the slots.
  - After installation, verify that the AP is securely fastened.
- 

### 3.4.2 Wall Mounting

- (1) Drill four 6.5 mm (0.26 in.) diameter holes in the wall and 53 mm (2.09 in.) apart, with the arrow on the mounting bracket facing up. Tap wall anchors into the holes, and drive screws through the mounting bracket into the anchors to secure the bracket.

**Figure 3-5 Attaching the Mounting Bracket to the Wall**

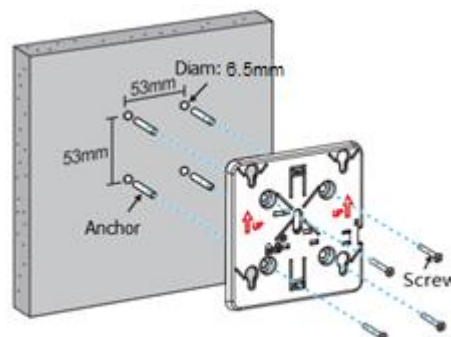

- (2) Align the square feet on the rear of the AP with the mounting holes on the bracket.

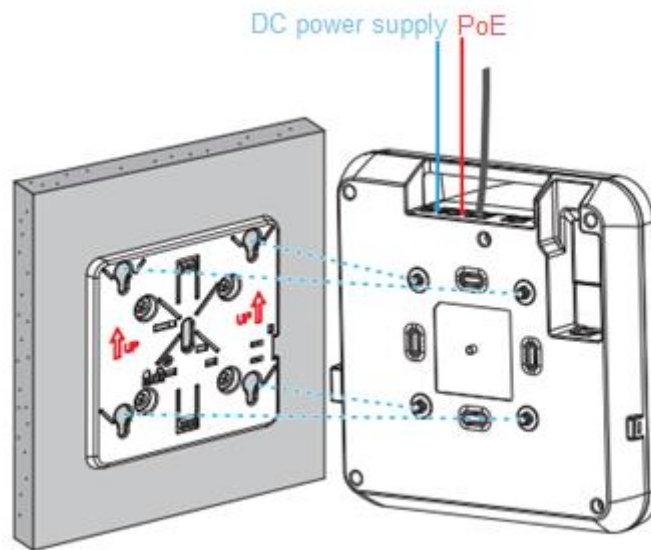
**Figure 3-6 Aligning the Square Feet with the Mounting Holes****⚠ Caution**

Install the Ethernet cables before mounting the AP on the bracket.

- (3) Slide the AP into the holes in the opposite direction of the arrows on the mounting bracket until it clicks into place.

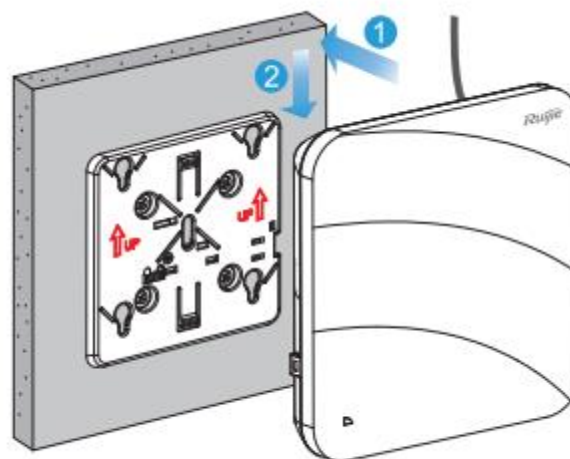
**Figure 3-7 Mounting the AP on the Bracket****⚠ Caution**

- When mounting the AP on the wall, keep the Ruijie logo pointed upwards.
- The square feet should fit easily into the mounting slots. Do not forcibly push the AP into the slots.

- After installation, verify that the AP is securely fastened.

### 3.5 Securing the Access Point

- (1) Loosen the screw on the mounting bracket and engage the security screw.

**Figure 3-8 Engaging the Security Screw**

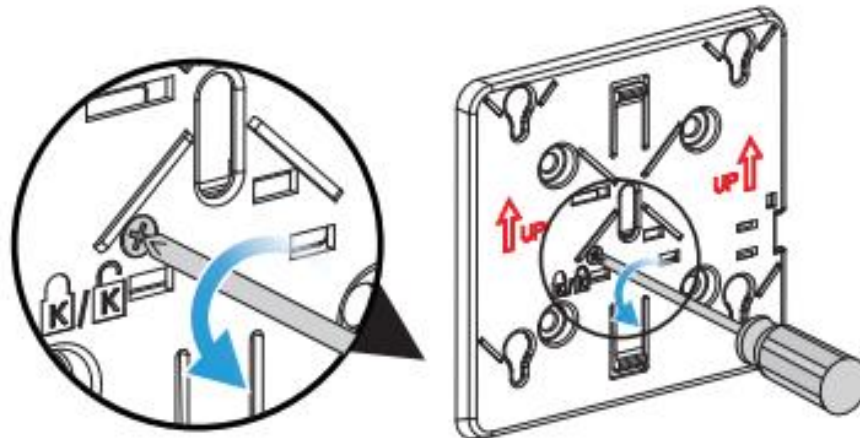

- (2) Align the square feet on the rear of the AP over the mounting holes on the bracket, slide the AP in the opposite direction of the arrows on the mounting bracket until it clicks into place.

**Figure 3-9 Mounting the AP on the Bracket**

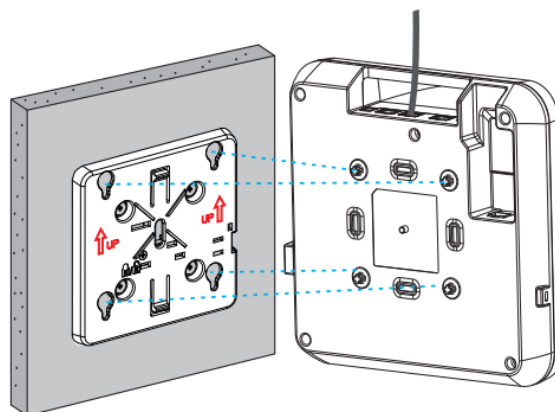

#### **⚠ Caution**

Install the Ethernet cables before mounting the AP on the bracket.

### 3.6 Installing the SFP Module

- (1) Insert the SFP module.

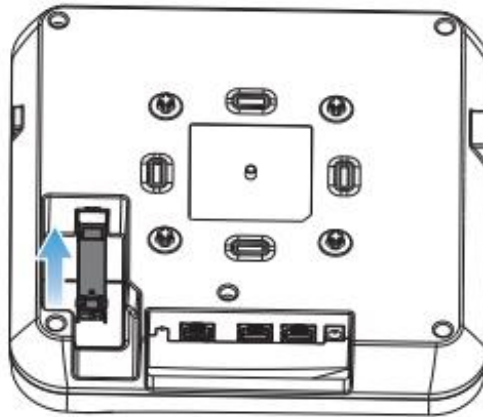
**Figure 3-10 Inserting the SFP Module**

(2) Connect the fiber.

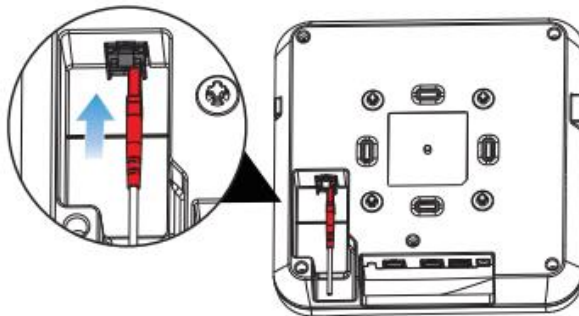
**Figure 3-11 Connecting the Fiber**

## 3.7 Removing the Access Point

(1) If the AP is installed on the ceiling, hold the AP in your hands and slide it sideways and away from the bracket in the LAN port direction.

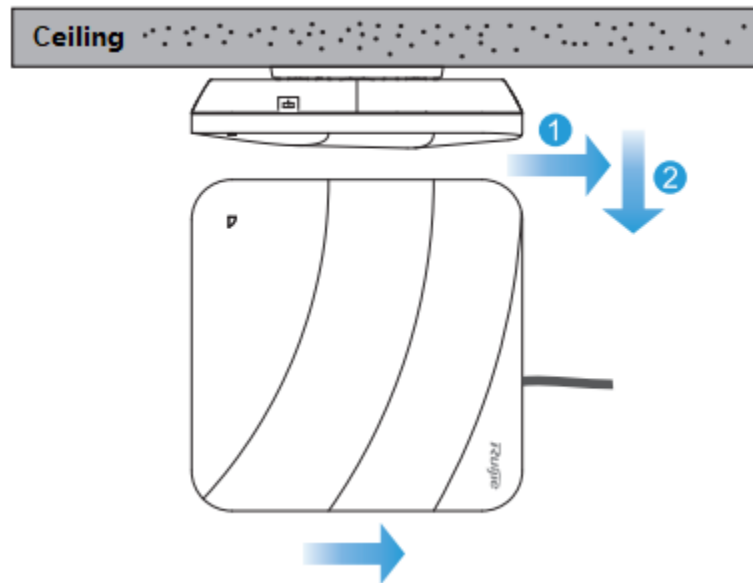

**Figure 3-12 Removing the Ceiling-mounted AP**

(2) If the AP is installed on the wall, hold the AP in your hands and push it upward and away from the bracket in the LAN port direction.

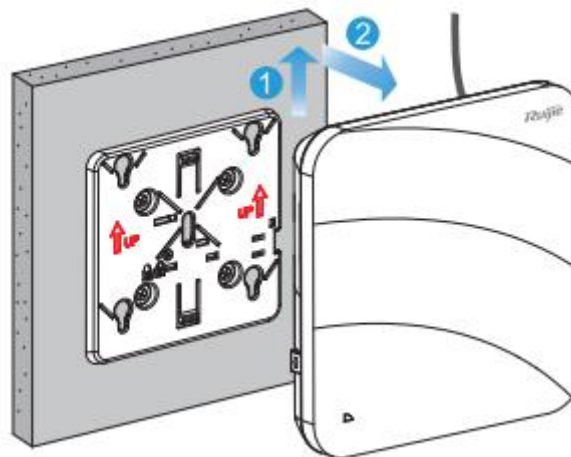
**Figure 3-13 Removing the Wall-mounted AP**

### 3.8 Connecting Cables

Connect UTP/STP to the LAN/PoE port on the AP. See Appendix A for supported wiring of twisted pairs.

**⚠ Caution**

By default, baud rate is set to 9600, data bit 8, parity none, stop bits 1 and flow control none on the Console port of the AP. The console port is used only when you want to configure the AP manually.

---

## 3.9 Bundling Cables

### 3.9.1 Precautions

- Make sure the cable bundles are neat and orderly.
- Bend twisted pairs naturally or to a large radius close to the connector.
- Do not over tighten cable bundle as it may reduce the cable life and performance.

### 3.9.2 Bundling Steps

- Bundle the drop UTP/STP cables and route them to the LAN/PoE port.
- Attach the cables in the cable tray of the rack.
- Extend the cables under the AP and run in straight line.

## 3.10 Checking after Installation

### 3.10.1 Checking Cable Connection

- Make sure the UTP/STP cable matches the interface type.
- Make sure cables are properly bundled.

### 3.10.2 Checking Power Supply

- Make sure all power ports are properly connected and compliant with safety requirement.
- Make sure the AP is operational after power-on.

# 4 Verifying Operating Status

## 4.1 (Optional) Configuring the Environment

Use a power adapter or PoE to power the AP.

### Setting up the Environment

- Verify that the AP is properly connected to the power source.
- Connect the AP to an AC through a twisted pair cable.
- When the AP is connected to a PC, verify that the PC and PoE switch are properly grounded.

## 4.2 Powering up the AP

### 4.2.1 Checking Environment before Power-on

- Verify that the power supply is properly connected.
- Verify that the input voltage matches the specification of the AP.

### 4.2.2 Checking Environment after Power-on

After power-on, you are advised to check the following to ensure normal operation of the AP.

- Check if any message is printed on the Web-based configuration interface of the device.
- Check if the LED works normally.

# 5 Monitoring and Maintenance

## 5.1 Monitoring

### 5.1.1 LED

You can observe the LED to monitor the AP in operation.

### 5.1.2 CLI Commands

You can run related commands on the command line interface (CLI) of the device to remotely monitor the configurations and status of the AP.

---

**i Note**

- You can log in to the AP via Telnet and use monitoring related commands to maintain the AP.
- 

## 5.2 Remote Maintenance

- If the AP operates as a Fat AP, you can log in to the AP remotely for maintenance.
- If the AP operates as a Fit AP, you can use AC to centrally manage and maintain the AP.

## 5.3 Hardware Maintenance

If the hardware is faulty, please contact our Technical Assistance Center (TAC) for help.

# 6 Troubleshooting

## 6.1 Troubleshooting Flowchart

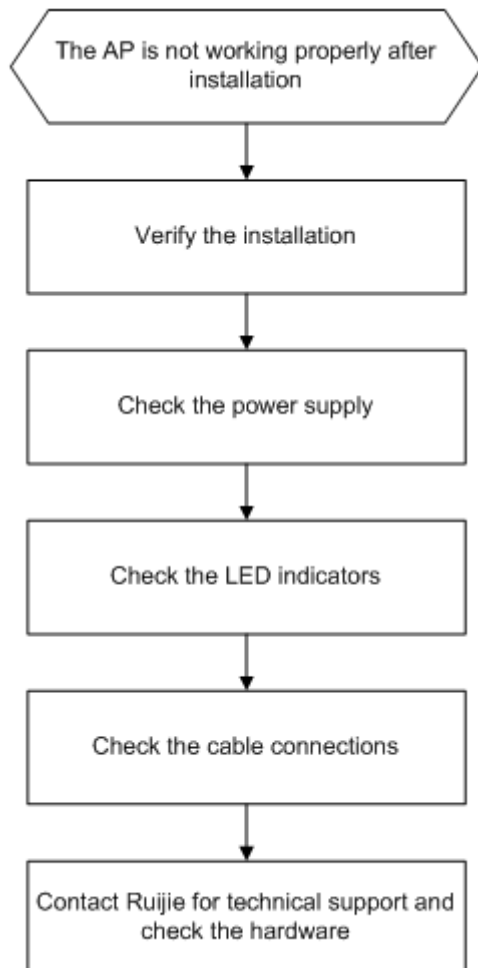

## 6.2 Troubleshooting

### 6.2.1 LED does not light up after the AP is powered on

- If you use PoE power supply, verify that the power source is IEEE 802.11af compliant, and then verify that the cable is connected properly.
- If you use a power adapter, verify that the power adapter is connected to an active power outlet, and then verify that the power adapter works properly.

## 6.2.2 Ethernet port is not working after the Ethernet cable is plugged in

Verify that the device at the other end of the Ethernet cable is working properly. And then verify that the Ethernet cable is capable of providing the required data rate and is properly connected.

## 6.2.3 Wireless client cannot find the AP

- (1) Verify that the device is properly powered.
- (2) Verify that the Ethernet port is correctly connected.
- (3) Verify that the AP is correctly configured.
- (4) Move the client device to adjust the distance between the client and the AP.

## 6.2.4 LED keeps blinking red

The LED stays blinking red for a long time, indicating the Ethernet port is not connected. Verify the Ethernet connection.

## 6.2.5 LED keeps blinking green

The AP performs initialization after power on. During this period, the LED keeps blinking green and does not turn solid until the initialization is completed. **Note:** If the blinking persists for an hour, it indicates the device initialization fails and the device is faulty.

## 6.2.6 LED keeps blinking orange (Fit AP mode)

Sometimes the AP performs firmware upgrade after power on. During this period, the LED keeps blinking orange and does not turn solid until the upgrade is completed. **Note:** Do not plug or unplug the power cord when the Status LED is blinking as firmware update takes time. If the blinking persists for ten minutes, it indicates the device fails to complete firmware upgrade and is faulty.

## 6.2.7 LED does not turn solid blue or blinking blue

After the system starts and the LED does not turn solid blue or blinking blue, probably because the AP has not established a proper CAPWAP connection with the AC. Verify the AC is operational and configured properly.



# 7 Appendix

## 7.1 Connectors and Media

### 1000BASE-T/100BASE-TX/10BASE-T

The 1000BASE-T/100BASE-TX/10BASE-T is a 10/100/1000 Mbps auto-negotiation port that supports auto MDI/MDIX.

Compliant with IEEE 802.3ab, 1000BASE-T requires Category 5e 100-ohm UTP or STP (STP is recommended) with a maximum distance of 100 meters (328 feet).

1000BASE-T requires all four pairs of wires be connected for data transmission, as shown in Figure 7-1.

Figure 7-1 1000BASE-T Connection

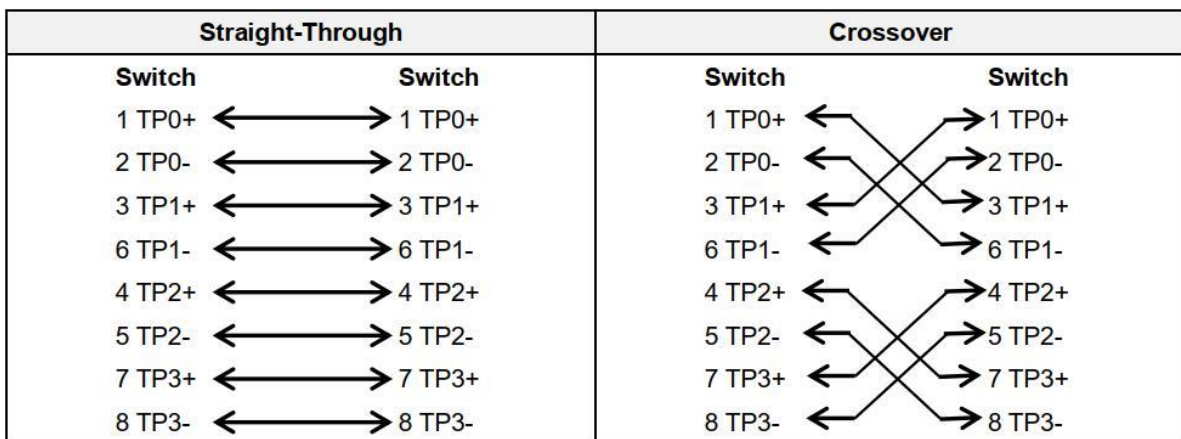

10BASE-T uses Category 3, 4, 5 100-ohm UTP/STP and 1000BASE-T uses Category 5 100-ohm UTP/STP for connections. Both support a maximum length of 100 meters. Figure 7-2 shows 100BASE-TX/10BASE-T pin assignments.

Figure 7-2 100BASE-TX/10BASE-T Pin Assignments

Pin	Socket	Plug
1	Input Receive Data+	Output Transmit Data+
2	Input Receive Data-	Output Transmit Data-
3	Output Transmit Data+	Input Receive Data+
6	Output Transmit Data-	Input Receive Data-
4,5,7,8	Not used	Not used

Figure 7-3 shows wiring of straight-through and crossover cables for 100BASE-TX/10BASE-T.



**Figure 7-3 100BASE-TX/10BASE-T Connection**

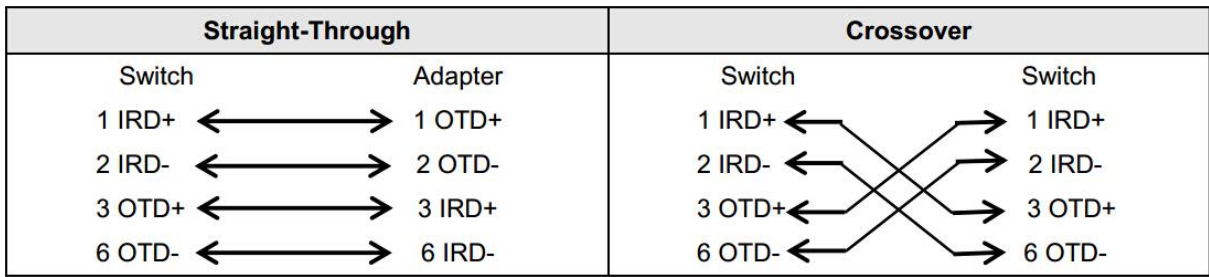

## 7.2 Mini-GBIC Modules

We provide appropriate SFP modules (Mini-GBIC) modules according to the port types. You can select the module to suit your specific needs. The following models and technical specifications of some SFP modules are listed for your reference.

**Table 7-1 Models and Technical Specifications of the SFP Module**

Wavele ngth (nm)	Media Type	Suppo rt DDM (Yes/No)	Intensity of Transmitted Light (dBm)		Intensity of Received Light (dBm)	
			min	max	min	max
1310Tx/ 1550Rx	Single- mode fiber	No	-9	-3	-	-18

**Table 7-2 Cabling Specifications of the SFP Module**

Port	Media Type	Core Size ( $\mu\text{m}$ )	Cabling Distance
LC	Single-mode fiber	9/125	0.3 km

### Caution

- For the fiber module with transmission distance exceeding 40 km and more, one on-line optical attenuator should be added on the link to avoid the overload of the optical receiver when short single-mode optical fibers are used.
- Fiber modules generate laser. Do not stare at light source.
- To keep fiber modules clean, please use dust caps when the modules are not connected with fibers.

## 7.3 Cabling Recommendations

During installation, route cable bundles upward or downward along the sides of the rack depending on the actual situation in the equipment room. All cable connectors should be placed at the bottom of the cabinet rather than be exposed outside of the cabinet. Power cords should be routed upward or downward beside the cabinet close to the location of the DC power distribution cabinet, AC power outlet, or lightning protection box.

- Required Minimum Cable Bend Radius
  - The minimum bend radius of a power, communication or flat cable should be 5 times the overall diameter of the cable. If the cable is constantly bent, plugged or unplugged, the bend radius should be 7 times the overall diameter.
  - The minimum bend radius of a coaxial cable should be 7 times the overall diameter of the cable. If the cable is constantly bent, plugged or unplugged, the bend radius should be 10 times the overall diameter.
  - The minimum bend radius of a high-speed cable, such as an SFP+ cable should be 5 times the overall diameter of the cable. If the cable is constantly bent, plugged or unplugged, the bend radius should be 10 times the overall diameter.
- Precautions for Cable Bundling
  - Before bundling cables, correctly mark labels and stick the labels to cables where appropriate.
  - Cables should be neatly and properly bundled, as shown in **Figure 7-4**.

**Figure 7-4 Bundling Cables**

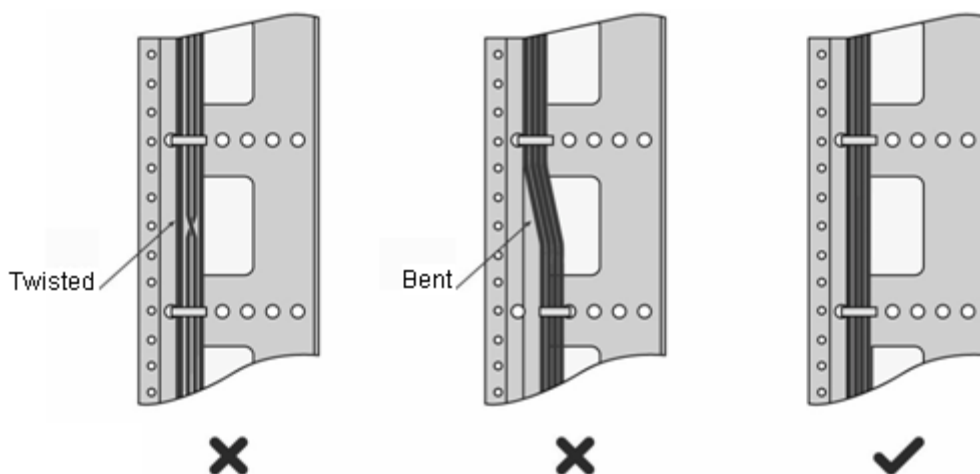

- Route and bundle power, signal, ground cables separately. When the cables are close to each other, cross them. When power cords run parallel to signal cables, the

distance between them must be greater than 30 mm.

- o All cable trays and their accessories shall be smooth and free from sharp edges.
- o Holes in metal, through which cables pass shall have smooth, well-rounded surfaces or be protected with insulating bushings.
- o Use proper cable ties to bind cables together. Do not tie two or more cable ties to bind cables.
- o Cut off excess cable tie cleanly with no sharp edges after bundling cables, as shown in Figure B-2.

**Figure 7-5 Cutting off Excess Cable Tie**

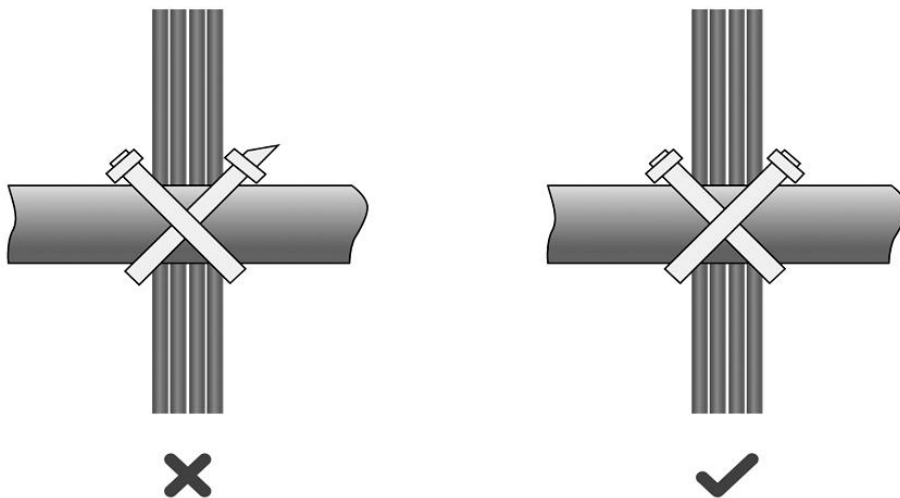

- o If cables are to be bent, bind them first but do not tie cable ties within the bend to avoid stress on the cables, which may otherwise cause the wires inside to break, as shown in Figure 7-6.

**Figure 7-6 Do Not Tie Cable Ties within the Bend**

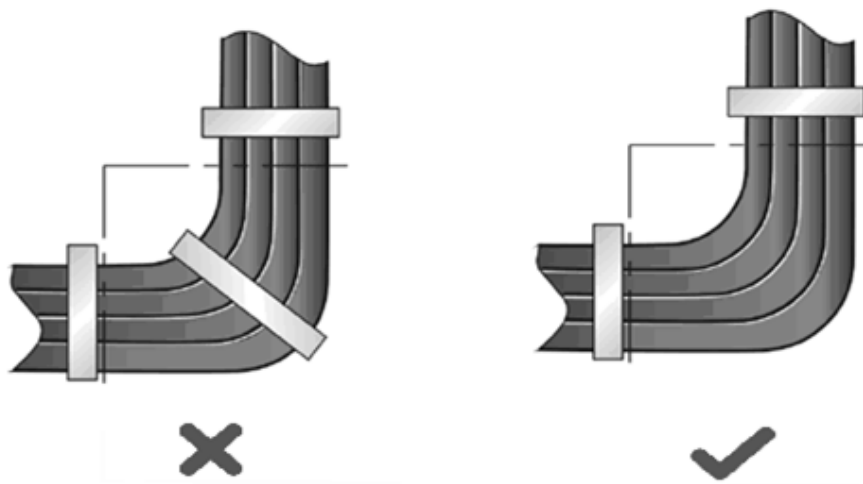

- o Wrap up unnecessary or excess cables and bind them to the appropriate rack position, where device operation is not affected and no damages occur to the device

and cables during debugging.

- o Do not bind power cords to the rails for moving parts.
- o Leave a certain length of the cable connecting moving parts, such as the ground wire of the cabinet door, to avoid stress on the cable; when moving parts are in place, ensure the excess cable length shall not contact heat sources, sharp corners or edges. If heat sources are unavoidable, use high-temperature cables instead.
- o When using screws to fasten cable lugs, the bolts or nuts shall be tightened and prevented from loosening, as shown in **Figure 7-7**.

**Figure 7-7 Fastening Cable Lugs**

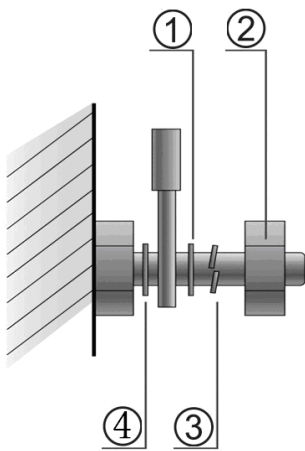

<b>Not e</b>	1. Flat washer	3. Spring washer
	2. Nut	4. Flat washer

- o When using a stiff cable, fix it near the cable lug to avoid stress on the lug and cable.
- o Do not use self-tapping screws to fasten terminals.
- o Bundle cables of the same type and running in the same direction into groups. Keep cables clean and straight.
- o Cables shall be tied according to the following table.

Diameter of Cable Bundle (mm)	Space between Bundles (mm)
10	80 to 150
10 to 30	150 to 200
30	200 to 300

- o Do not tie knots for cables or cable bundles.

- The metal parts of the cold-pressed terminal blocks, such as air circuit breakers, shall not be exposed outside of the blocks.

## 7.4 Power Supply

- DC power adapter:

Input voltage: 48 V

Rated current: 0.6 A

- Technical Specifications of the DC Power Connector

Inner Diameter	Outer Diameter	Depth	Polarity
2.0 mm (0.08 in.)	6.3 mm (0.25 in.)	9.8 mm (0.39 in.)	Inner pole: positive Outer pole: negative

