

Installers & User guide **Keybox 2.**

Welcome!

This guide will get you up and running with your igloohome Keybox 2. In the meantime, you should follow igloohome on Facebook and Youtube!



Like us on Facebook



Visit our Youtube

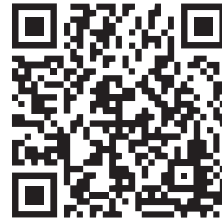

As our igloohome app is frequently updated, there may be changes to this manual. Please refer to our website igloohome.co/support for the latest version of the manual.

Table of Contents

What's Included	4
Specifications	5
Features	6
Lock Behaviour	7
Quick Start Guide	8
App Onboarding	9
Unlocking	10
Locking	11
Lock Installation	12
Managing Access in App	14
Lock Tutorial	15
Airbnb Connect	16
Troubleshoot	17

What's Included

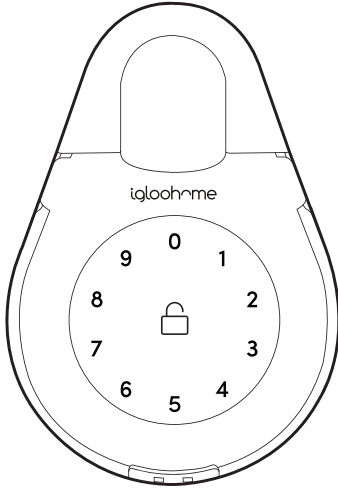

Keybox 2

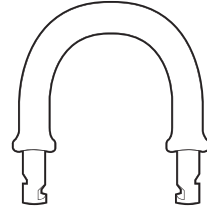

Slim Shackle

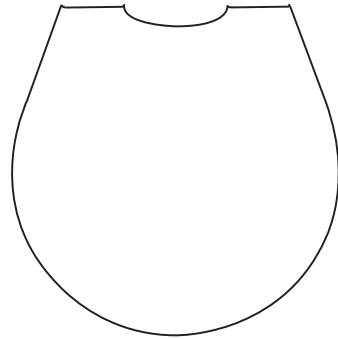

Rain Cover



Mounting Seal Rings x4



Rubber Studs x6

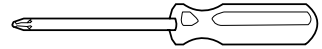

Screwdriver



Mounting Screws x4



Screws Anchors x4



**Battery Cover
Spare Screws x4**

Specifications

Model	igloohome Smart Keybox 2
Shackle Dimensions	46mm (1-13/16") Width x 36mm (1-7/16") Height
Slim Shackle Dimensions	40mm (1-9/16") Width x 63mm (2-1/2") Height
Inner Storage Space	108mm (4-1/4") x 75mm (3") x 16mm (5/8")
Material	Zinc Alloy, ABS, Hardened Steel
Net Weight	1kg (2.2lbs)
Current Rating (Standby)	~20uA
Current Rating (Active)	~20mA
Batteries	4 x AAA* Alkaline Batteries
Battery Life	Up to 9 Months
Unlock Mechanism	Bluetooth, PIN code

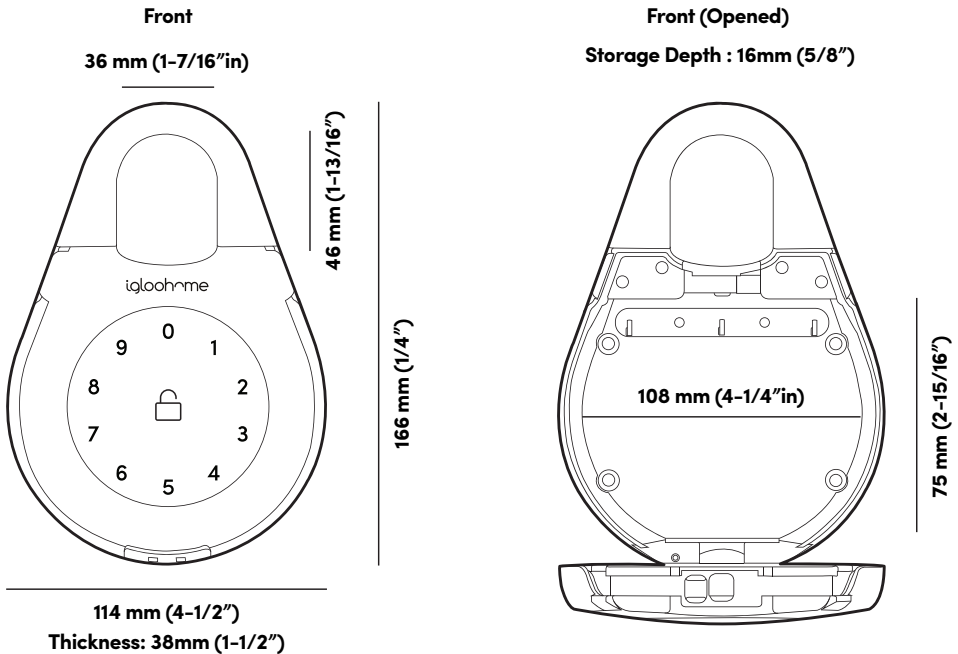

* **DO NOT USE:** Heavy Duty, Eveready, GP, or rechargeable batteries. Duracell & Energizer alkaline batteries recommended. Please note that using better batteries will improve the performance and lifespan of the lock.

Features

PIN / Bluetooth Unlock



Master PIN Code

The igloohome Smart Keybox 2 unlocks with a permanent Master PIN Code.



User PIN Code

The igloohome mobile app can generate 3 types of User Pin codes (One-Time, Permanent or Duration).



Bluetooth Master Key

The igloohome Smart Keybox 2 unlocks with Bluetooth via the app.



Bluetooth Guest Key

The igloohome mobile app can generate and share Bluetooth keys (based on duration) with guests to unlock the Smart Keybox 2.



Cloud Backup of Master Access

Master access is tied to user account instead of phone. Any phones logged in to user account will have full control of the lock.

Note: Multiple phones can log into the same account. To give admin control to another party, you may share with them your login credentials.

Battery



Battery Life

The Keybox 2 can last up to 9 months with 4 x AAA alkaline batteries.



Emergency Jump Start

If battery power is drained, an external 9 Volt battery can be used to provide emergency power. The 2 contact points of the battery must be aligned with the 2 contact points on the Keybox as shown in page 17.



Low Battery Indicator

LED light changes to red light when battery level is low. The battery level can also be monitored on the app and is updated during Bluetooth Unlock.

Features

Security



Security Alarm

If the Keybox is not closed properly, it will beep to indicate that it is not secure.



Decoy Code

A total of 16 decoy digits including PIN code can be entered to prevent the PIN code from being exposed.



Automatic Re-lock

If Keybox is unlocked but remains un-opened for 60 seconds, it will automatically re-lock.

Lock Behaviour

Security Lockout Mode	
Activated by	5 consecutive invalid PIN codes
Disable By	Wait for 5 Minutes or Bluetooth Unlock
Behaviour	Keypad is flickering
Duration	Unresponsive for 5 minutes

Quick Start Guide

1 Remove 4 screws and battery cover

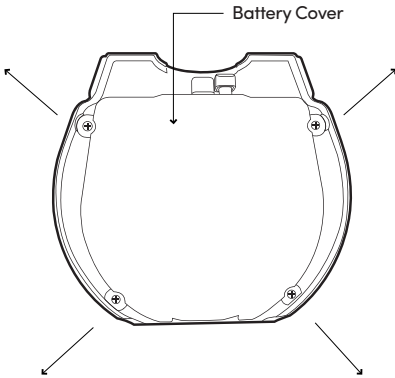

2 Insert AAA Batteries

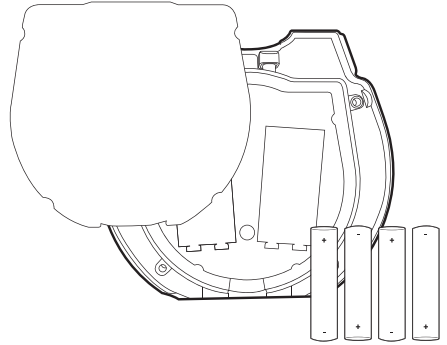

3 Secure battery cover tightly with 4 screws

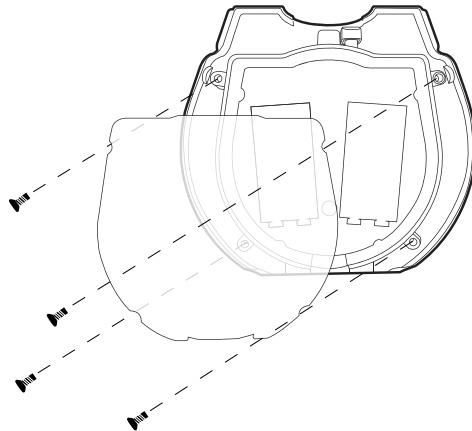

App Onboarding

1 Test Factory PIN Unlock

In the factory mode (before pairing), the PIN to unlock the lock is **1 2 3 4** 

2 Register as a Lock User

- Download igloohome from the App Store / Play Store
 - Create an account and login
-

3 Pairing

- Select **[Add new igloohome lock]**

Note: For existing users with other paired locks, go to **[Configuration]**, select **[Manage Locks]** followed by the **[Add]** icon.

- Select **[igloohome Keybox 2]**
- Place your palm over keypad to wake device up
- Press **[Next]** and select the lock to pair with.

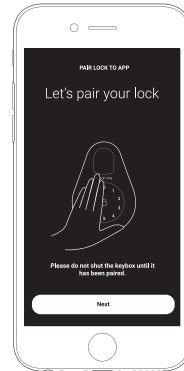

4 Setting Master PIN Code

Before proceeding, turn on your Bluetooth and ensure that you are within Bluetooth range of the lock.

Go to **[Access]** and customize your **[Master PIN]** by editing it.

Unlocking

a Bluetooth Unlock

1. Open your igloohome app
2. Tap on the "Bluetooth Unlock" button
3. Wait for a long beep after 1 to 2 seconds
4. Pull the tabs of the side to open the lock (see image below)

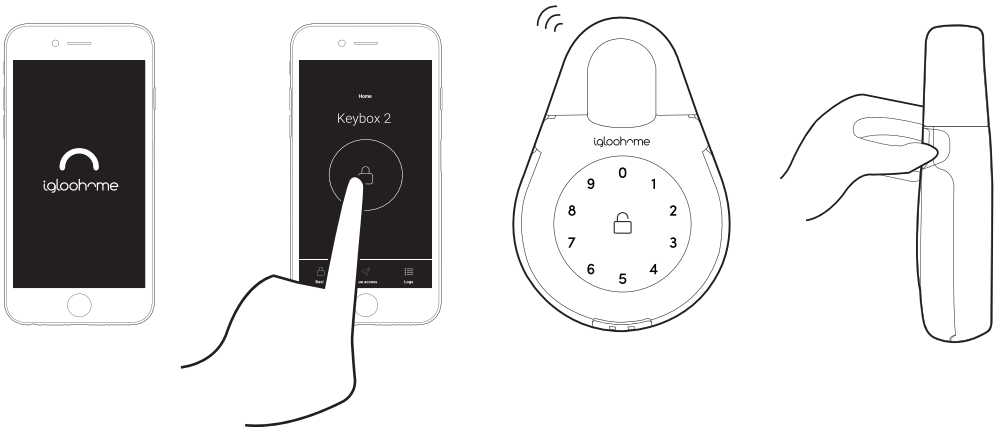

b PIN Code

1. Place your palm over keypad to wake device up
2. Key in a valid PIN code (with or without decoy pins) followed by the "Unlock Icon"
3. Wait for a long beep after 1 to 2 seconds and the LED to go off
4. Pull the tabs of the side to open the lock (see image below)

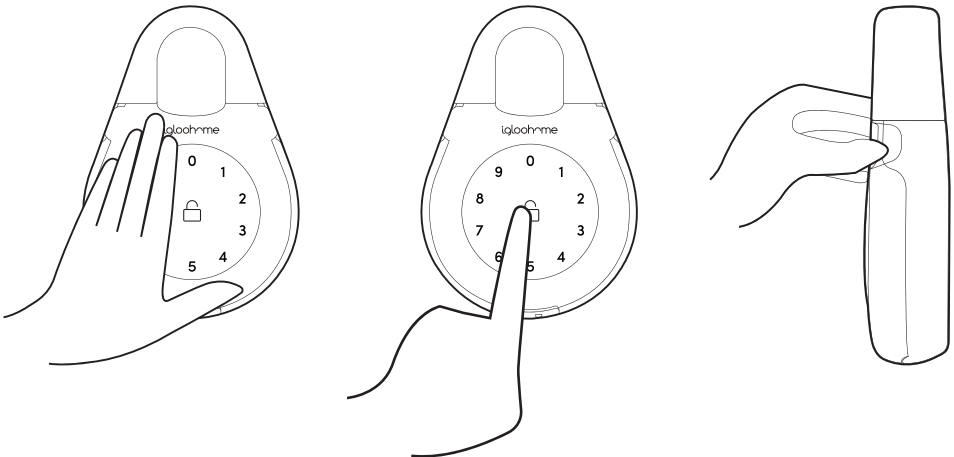

Locking

1. Simply close the keybox tightly
2. Wait for a long beep after 1 to 2 seconds

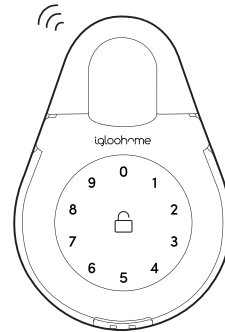
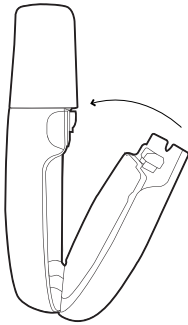

Lock Installation

a Secure Keybox on a handle or knob

1. Unlock the keybox
2. Push the shackle release to the right
3. Pull out the shackle
4. Secure on a handle or knob
5. Insert back the shackle
6. Insert the Rubber Studs in the holes

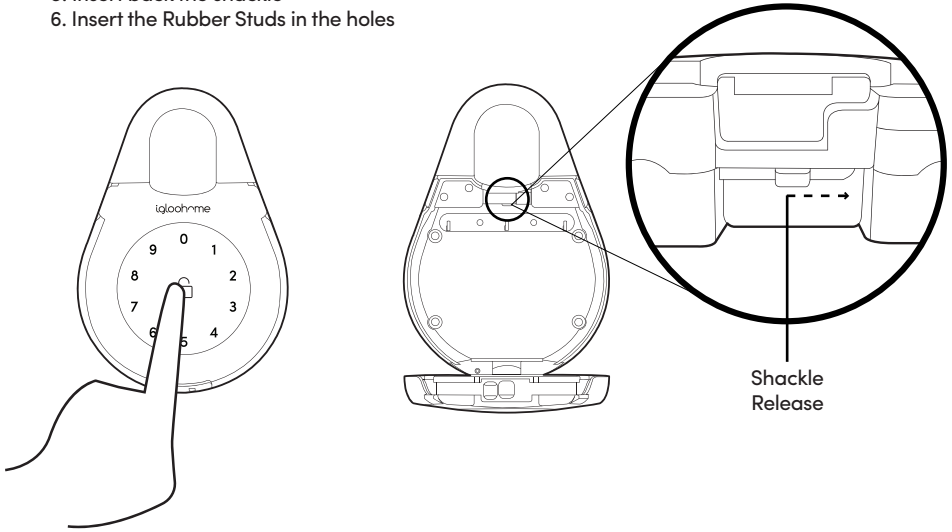

For door handles

For door knobs,
use Slim Shackle

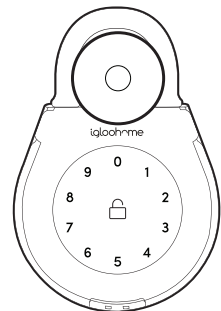
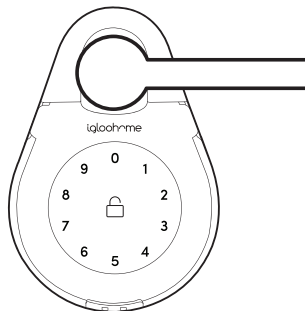
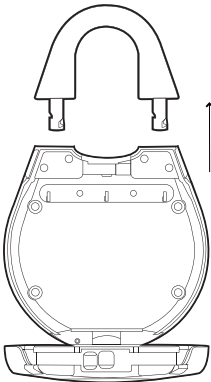

b**Mount on a surface**

1. Unlock the keybox
2. Drill holes on a wall
3. Hammer the screw anchors into the holes
4. Mount the Keybox 2 on the wall with the mounting seal rings and 4 screws

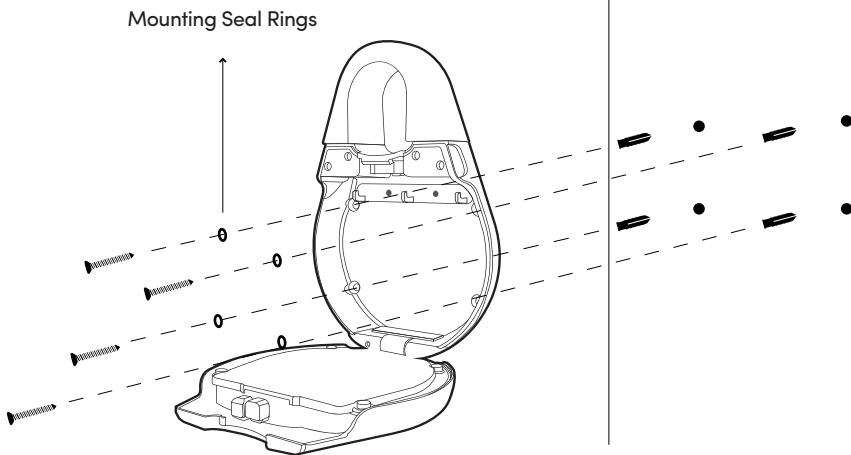
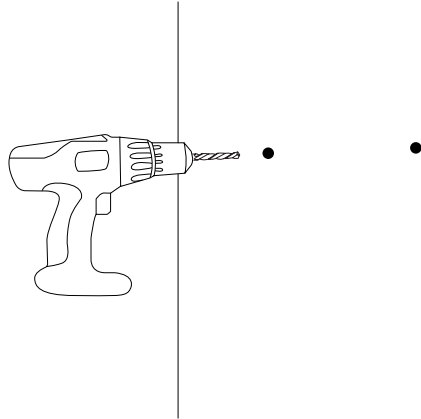
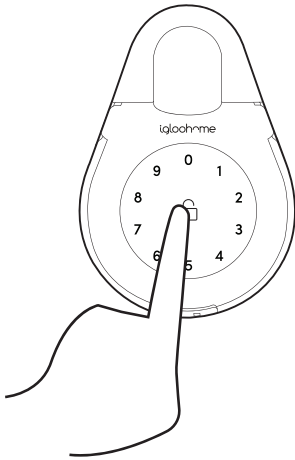

Managing Access in App

1 Creating PIN codes

PIN codes can be generated on the app under **[Access]**, create **[New Key]** and choose either One-Time, Permanent or Duration PIN.

Pin codes will expire if its not use within its activation period. Refer to the table below.

PIN Type	Use PIN within*
One-Time PIN	6 hrs of generation
Permanent PIN	24hrs of generation
Duration PIN	24hrs from the start time

2 Bluetooth Guest Key

Bluetooth Guest Key can be shared with other users for mobile access. It allows your guests to unlock the igloohome smart lock via Bluetooth.

There are 3 steps to using a Shared Bluetooth Key

- Under **[Access]**, create **[New Key]** and choose **[Bluetooth Key]** under **[Access Type]**. Proceed to share the key after it is created.
- Guest receives the Bluetooth Key by one of these methods:
 - Clicking the URL given and follow the instructions.
 - Scanning the QR code under **[Visits]**.
- Guest can now use the Bluetooth Key under **[Visits]** whenever he is within range of the lock.

Notes:

- The owner can revoke the Bluetooth Key in App.
- Bluetooth Key must be accepted within 1 hour generation before it expires.

3 Resetting PIN Codes

Ensure that Bluetooth is switched on, and you are within Bluetooth range of the lock.

Go to Home > Select Lock Name > **[Settings]** > Reset Pins





Lock will reset all codes, except for Master PIN, and all PIN codes previously generated are no longer valid.

Lock Tutorial

1 Edit PIN

Once PIN code is generated, user must key the generated code onto the keypad followed by  to activate the code before proceeding. To change the PIN, enter:

Press  for **2 seconds** > **Key 1 0** and tap  > **Current PIN** and tap  > **New 4-9 digit PIN** and tap  > **New 4-9 digit PIN** and tap 

Current PIN Code	1234 5678
New PIN Code	010101
On Keypad	Press  for 2 seconds > Key 1 0  > 1234 5678  > 010101  > 010101 

Notes:

- Editing of PIN codes can also be done in app.
- PINs must be used once before it can be edited.

2 9V Jumpstart Feature

1. Touch and hold the battery contacts against the 9V jumpstart pin on the lock.
2. While holding the 9V battery to the jumpstart, key in PIN code on the keypad followed by  to unlock.

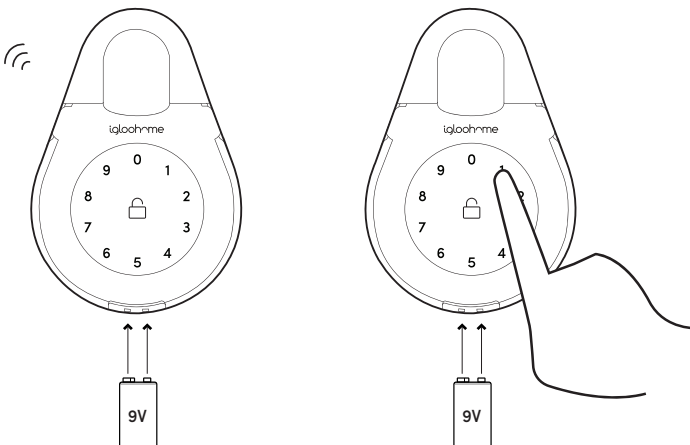

Airbnb Connect

1

Airbnb Connect

Airbnb Connect automates the generation of PIN codes for your Airbnb guests based on their approved reservations. It costs USD\$4.99 per month, but is currently on free trial.

Here are the steps to activate Airbnb Connect

Step 1: Connect to your Airbnb

Under **[Account Settings]**, select **[Connect with Airbnb]**

Step 2: Connect to Airbnb listings

Under **[Reservations]**, click the **[Add]** icon to select a home to connect to. Select Airbnb Listing and PIN Time to associate.

Note:

- Emails with PIN code will be sent to the guest between 1 to 48 hours before check-in time (configurable).
- PINs will only be valid between the check-in and check-out times.

Step 3: Change Check-in and Check-out time

Under **[Configuration]**, select **[Manage Homes]** followed by the listing to view or edit its details.

Notes:

- If the access mail has not been sent, changing your check-in/check-out time via the app modifies the start and end time of the PIN codes to be shared with your guest.
- If the access mail has been sent, changing these details will only affect the next reservation.
- Changing these details on the igloohome app does not update the check-in/check-out time on the listing on the Airbnb website.

2

Disconnect Airbnb

Should you prefer to generate PIN codes for your guests manually, you may disconnect your Airbnb listing from the igloohome home listing with the steps below.

1. Under **[Reservations]**, disconnect all the listings (if any).
2. Under **[Account Settings]**, select **[Disconnect with Airbnb]**.

Should you wish to completely disconnect your Airbnb account from your igloohome account, make sure that all your Airbnb listings have been disconnected in the above step, then go to:

Airbnb Host Website > Connected Apps > Select igloohome to disconnect

Troubleshoot

Pairing is unsuccessful

- Try with a different mobile device, using the same username and password
- Update your phone's Operating system to the latest version
- Restart the Bluetooth and internet connection on your mobile device
- Restart igloohome app on your mobile device
- Switch to a new set of batteries

Keypad does not light up

- Use a 9V battery to jumpstart and switch to a new set of batteries
- Ensure that your Keybox has not been placed outdoors / exposed to weather elements

Keypad is flickering

- The Keybox is low in battery. Switch to a new set of batteries
- Ensure that your Keybox has not been placed outdoors / exposed to weather elements

Generated PIN codes do not work

- Make sure that the generated PIN codes are activated within the given hours
- Do a Bluetooth Unlock to refresh the app
- PIN codes may have been customised or expired
- Ensure that your Keybox has not been placed outdoors / exposed to weather elements

Keypad lights up on touch but does not beep

- Check if the Keybox is in security lockout mode (See Pg. 7)

Lock is not working when battery level is not 100%

- Do a Bluetooth Key unlock to refresh the battery level on the app
- Battery level shown in the app may not be accurate
- Use Alkaline batteries only
- Do not use: Heavy Duty, Eveready, GP, or rechargeable batteries
- Ensure that your Keybox has not been placed outdoors / exposed to weather elements

** Using high quality batteries will improve the performance and lifespan of the lock*

Bluetooth Key is not working

- Restart the Bluetooth and internet connection on your mobile device
- Check on the timezone of the home listing against your phone time
- Check if the Bluetooth Key is expired. It must be accepted within 1 hour of generation
- Update your igloohome app to the latest version
- Switch to a new set of batteries
- Ensure that your Keybox has not been placed outdoors / exposed to weather elements

Re-lock is not working

- Check battery level of the lock
- Ensure you have installed the battery cover correctly
- Ensure 9V contact points are not damaged

Changing Batteries

- To open the battery compartment, unlock the keybox and twist the battery cover clockwise to loosen
- Replace all 4 batteries, and put the battery cover back on by twisting counterclockwise

For enquiries go to:
igloohome.co/support